

WHY SPG?

SOCIAL
RESPONSIBILITY

PASSION FOR
PERFORMANCE



SPACE OPTIMIZATION
PROVEN SYSTEMS
ERGONOMICS

ECONOMIC BENEFITS CAPACITY

INNOVATION
ETHICAL SOURCING
MADE IN THE USA

OPERATIONAL EFFICIENCY
CUSTOMER SATISFACTION

WORLD CLASS
SECTORS

DURABILITY
LOWEST COST
OF OWNERSHIP



QUALITY
MANUFACTURING
SUSTAINABILITY



SERVICE

GLOBAL PARTNERS
ELITE ENGINEERS

EXPECT MORE
SPGTM
STORAGE PRODUCTS GROUP

Raising the bar for quality equipment, while lowering the total cost of ownership.

The SPG name has only been around since 2010, however the product lines that comprise our company have been among the most well-known and respected names in the foodservice business for nearly six decades. Individually, each of the product lines below brings unique expertise, capabilities and quality to foodservice operations. Together, they offer you a total turnkey solution.

AMCO®: The industry leader in premium shelving, equipment and accessories that utilize an ultra-strong square-post system.

ISS™: Strong, versatile wire-based shelving, wall storage systems, carts, racks, dollies, workstations and more.

ISS Contender™: The industry's workhorse in wire shelving and accessories — the ideal choice for general applications.

Freestyle®: Strong, versatile and space-efficient, Freestyle® freestanding cantilever shelving and workstations provide maximum performance for every area of your operations.

Kelmax: The gold standard in aluminum equipment — from storage and transport to specialty items for everything from produce and bakery to material handling.

Universal® Stainless: The stainless steel fabrication specialists — offering a vast array of sinks, tables, cabinets, shelves, racks, stands, counters and more.

Gillis & Jarke®: SPG's two material handling lines deliver equipment that's tough, durable, innovative, efficient and economical.

Together, the SPG product lines create unique synergies and efficiencies that enable SPG to deliver an extraordinary array of service and products to your organization. With the broadest selection of foodservice equipment available anywhere, only SPG can offer you so many choices that lead to greater productivity, profitability, performance — and the lowest cost of ownership.

Optimizing the performance and efficiency of your operation.

Nobody offers you more choices in storage equipment, or better ways to optimize the productivity and value of your space, personnel and investment.

SPG storage solutions are specifically designed to not only help you put more into every square foot, but they're also easier to access, clean and assemble. Whether it's in the food prep, drive-thru or any other area of your operation, SPG equipment is designed to fit your space, and the way you do business — reducing the time, motion and effort your staff needs to complete a task. And SPG products are built to be stronger — and last longer — by virtue of the strict manufacturing processes we employ and the quality and amount of material we put into each product.

If you want to get more out of your equipment, contact your SPG representative to see all we can do to optimize your foodservice operation.



You'll find a lot of amazing products in this catalog. But only a fraction of the amazing products we make.

As you look through these pages, bear in mind that the products shown are representative of the far greater number of solutions we offer. For any item you see, there may be dozens, hundreds — or even thousands — of additional products we can provide. SPG offers different sizes, materials, finishes, configurations and accessories to ensure you get the equipment that best fits your needs and your business.

If you don't see exactly what you want in these pages, ask your SPG representative about it. With the broadest selection of foodservice equipment, chances are we already make whatever you're looking for — and can provide it to you through your SPG representative.

See "How to Choose Shelving" on pages 10-11

Shelving	Wire	12-18
	Plastic	19-22
	Aluminum	23-24
	Cantilever	25-30
	Wall Systems	31-36
	Security/High-Density	37-38
	Workstations	39-40
Speed Of Service	41-42	
Carts	43-48	
Racks	49-54	
Tables	55-62	
Sinks	63-64	
Bar Equipment	65-66	
Backroom	67-68	
Accessories	69-82	

For customer service and more information, contact us toll-free:

(877)503-4SPG (877-503-4774)

Email us at: customerservice@spgusa.com



SPG's foodservice products are all manufactured to meet NSF standards. For specific items, visit www.nsf.org



<http://www.youtube.com/user/StorageProductsGroup>

By creating efficiencies in our organization we can bring them to yours.

At SPG, every product we offer is designed and manufactured to provide immediate value when you buy it, and to continuously accelerate and maximize your ROI over time. To achieve this, we follow a strict, formalized process that results in the lowest cost of ownership for our customers, and that can only be achieved by a holistic approach that addresses three areas.

1. Quality Manufacturing

Incorporating best practices in manufacturing and quality control, we continually seek new efficiencies in production to drive out cost. At the same time, we use only high-quality material in our equipment — and we use more of it — to ensure our products hold more, last longer and provide enduring value.



From start to finish, SPG's adheres to best practices in manufacturing and quality control to ensure excellent performance, enduring service and customer satisfaction.

The SPG Difference

Here's just a brief checklist of some of the ways SPG goes over and above our competitors to add value and lower the cost of ownership.

We Use More And Better Materials

- Premium 300 Series stainless steel
- Stronger welds
- More metal at key stress points
- 27% more metal in our AMCO® shelving posts
- Full-metal thickness throughout our sink bowls

We Offer Exclusive Patented Innovation

- Award-winning ergonomics
- Cooler/freezer capacity gains of 30% - 68%
- A pan rack with a 50% smaller storage footprint

We Deliver Total Solutions

- The broadest selection of storage products
- More choices to create custom solutions
- Consultative design services to maximize storage capacity, space utilization, staff productivity and more

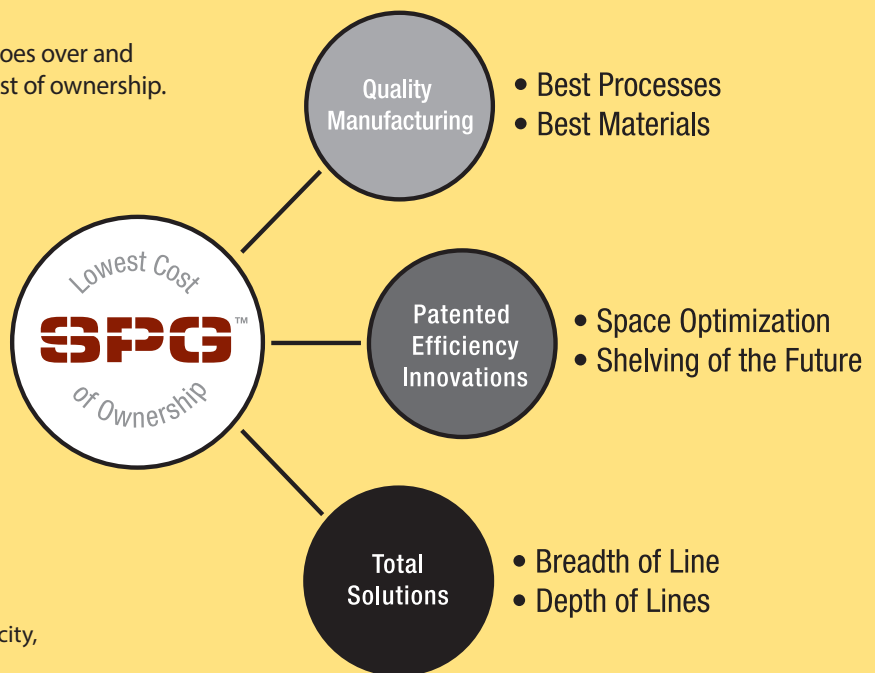

2. Patented Efficiency Innovations

Using input from customers, our products are designed by an elite engineering team using sophisticated tools. As a result, our products are fast and easy to set up... inventory is easier to access space is optimized...staff productivity is increased...and our scalable solutions can be reconfigured to meet your future needs.



The patented design of our Collapsible Nesting Mobile Pan Rack has won industry recognition for innovation and efficiency.



An uncompromising commitment to quality...exclusive leading-edge innovation...and the industry's widest selection of products—it all comes together to provide your business with the ultimate in storage solutions and the lowest cost of ownership. And we back it with the best guarantee in the business.

3. Total Solutions

Beyond our vast selection of equipment, SPG offers customized sizes and solutions...site design and consultative services...and the experience and technical expertise to help you get the most out of your space, your people and your investment.



SPG's products and solutions deliver operational efficiencies (See pages 6-7 for details).



SPG is a US based manufacturer with strategic global partnerships to serve the needs of multi-national brands. All SPG partners meet or exceed worldwide social, economic and environmental standards.



There are opportunities everywhere in your operation. We'll help you find them.

While we are happy to sell a customer a single piece of equipment, the real value we provide is our ability to analyze your operation and design a comprehensive solution customized to your unique needs. Working with you, we'll help you uncover the hidden opportunities that exist in your facilities. Then, we'll help you select the right systems and integrate them into your operation in a way that increases workflow, maximizes storage capacity, improves employee productivity, cuts costs and increases profitability.

We can offer you these services because SPG manufactures the widest selection of equipment solutions on the market. And, we match that selection with years of proven experience.

Our comprehensive product selection can provide an integrated system that encompasses every facet of your operations. From the backroom to the bakery to the bar...from the drive-thru to the dish and dry storage areas...we'll put together the equipment — and a comprehensive plan — that will help you maximize the efficiency and performance of your business.

Foodservice Floor Plan Guide

Area	Item Description	Page	Brand
Salad Prep	Cantilever Prep Workstation	38	Freestyle
	Wall-Trax Wall Grid System	31	ISS
	2-Comp Salad Prep Sink	63	Universal Stainless
Dish/Sink	Plastic Plus Mobile Dish Rack	20	AMCO
	Stainless Steel Cart	44	Kelmax
	Wall-Trax Wall Grid System	31	ISS
	3-Comp Dish Sink	63	Universal Stainless
Food Prep	Cantilever Prep Workstation	38	Freestyle
	Stainless Steel Cart	44	Kelmax
	Hand Sink	62	Universal Stainless
Dry Storage	Amtrax High Density Storage	37	AMCO
	Freestanding Wire Shelving	16	ISS Contender
Freezer	Aluminum Cantilever Shelving	28	Kelmax
	Aluminum Dunnage Shelving	51	Kelmax
	Mod-A-Flex Shelving	26	AMCO
Cooler	Gold Bond Wire Shelving	14	ISS
	Aluminum Pan Rack	48	Kelmax
Beer/Wine	Keg Rack	65	Kelmax
	New Era Plastic Shelving	18	ISS
Non-Food Storage	Plasteel Heavy Duty Shelving	21	AMCO
Dunnage Storage	Heavy Duty Plastic Dunnage	51	ISS
Drive-Thru	ISS Drive-Thru	40	ISS
	Hand Sink	62	Universal Stainless
	Condiment Stand — Order Stager	41	ISS
Take-Out Area	Take-Out Station	28	Kelmax
	Enclosure Cabinet	50	Kelmax
	Take 10 Can Rack	52	AMCO
Bulk Storage	Jarke Rack	*	Gillis & Jarke
	Utility Carts	42	Kelmax
Service Area	Front Counter Cart	41	ISS
Bakery Prep	Bakery Prep Ingredient Bins	73	Kelmax
	Equipment-Utility Carts	44	Kelmax
Manager's Office	Wire Workstations	40	ISS
Chemical/Mop Sink	Mop Sink & Chemical Storage	30	ISS

*Not shown in catalog.

Note: Gillis & Jarke® products are available in our Material Handling & Industrial Storage Solutions catalog. See our website.

Mod-A-Flex®
Cooler/Freezer



ISS™ Workstation
Drive-Thru



Wall Trax™
Salad Prep



AMCO® Take 10® Can Storage
Take-Out Area



Freestyle®
Food Prep

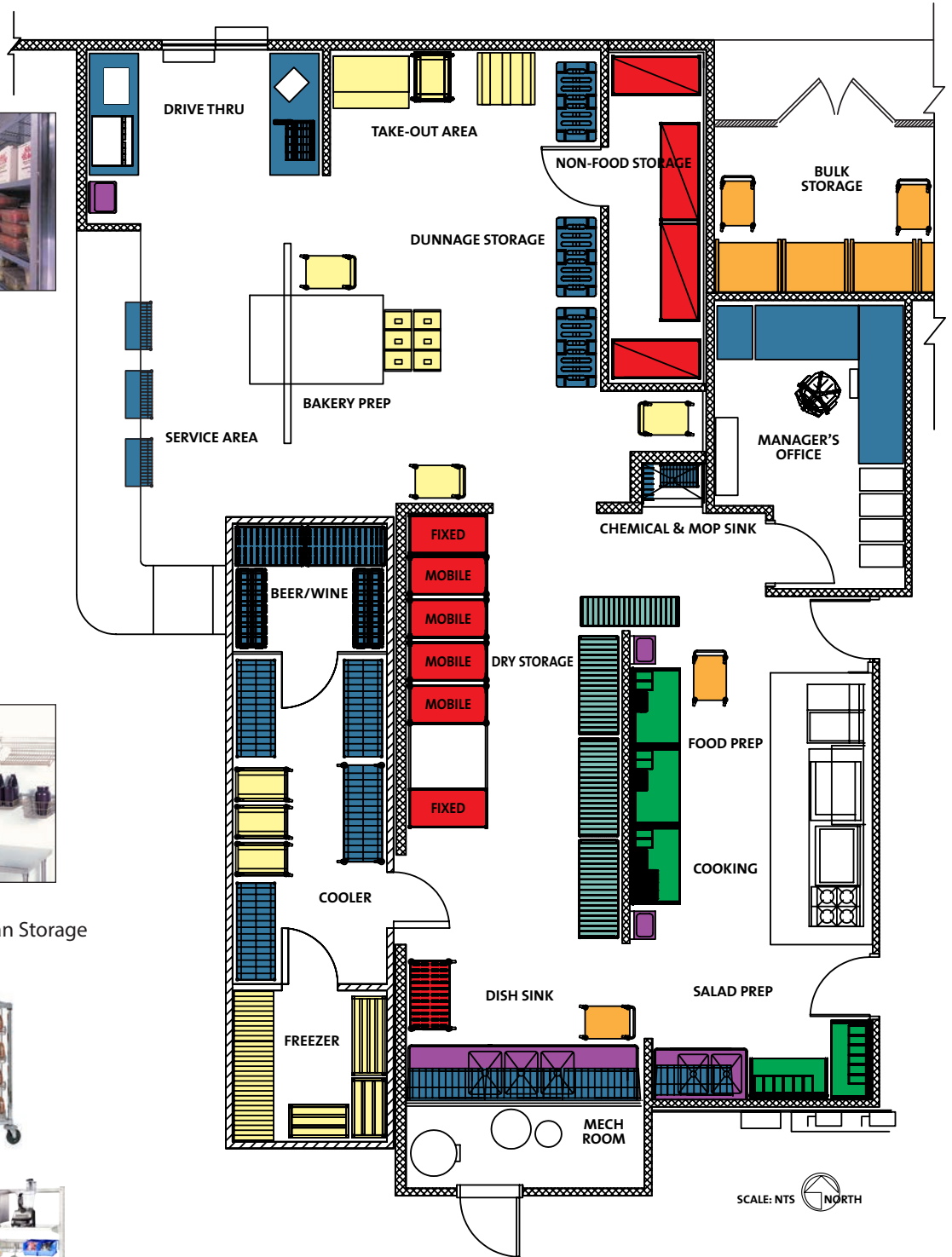

Sample Foodservice Floor Plan

Here's an illustration of the breadth of products we provide — and an example of the type of unified, highly efficient layout we can design for you.

SPG Innovation. Improving the performance of our foodservice equipment and the businesses who use it.

At SPG, we don't just build storage equipment, we create opportunities to help our customers become more efficient, productive and profitable. We accomplish that through the innovative manufacturing processes we have developed to minimize costs while maximizing quality — and by the innovative designs you'll find throughout all of the SPG product lines.

On these pages, you'll find just a few of the many ways SPG engineering and design have made a profound and profitable impact on the bottom line performance of our customers.



Improved productivity: SPG's Universal Stainless Adjustable Ergonomic Table and our Ergonomic Deli Slicer Table (Page 54) improve staff efficiency by providing a work surface that's customizable to the height and preferences of each employee.



Maximized space: The unique design of our Collapsible Nesting Mobile Pan Rack (Page 48) not only reduces the storage footprint by 50%, it also allows one person to move multiple units quickly and easily.



Look for this logo throughout the catalog — it signifies innovative design that's only available from SPG.

Creating value in every area of your operation.



SPG
PATENTED

Cut costs: In-store tests show SPG Freestyle® shelving (Page 24) has proven to provide more capacity in less space — lowering investment cost by increasing usable storage surface space in coolers by up to 68% and in freezers by up to 60%.

Increased capacity: Our new Freestyle® brace (Page 25) increases the load capacities of Freestyle® shelving even more — by up to 42% for the storage and display of heavy, high-density products.



SPG
PATENTED

Enhanced Versatility: The flexible design of the Kelmax Rocket Cart (Page 42) makes it a workhorse for moving all types of goods in all types of applications.



SPG offers the broadest range of storage systems in the market, and we continue to add to your choices with intelligently designed products to help you run a more efficient and profitable foodservice operation.

Strength, durability, performance and the lowest cost of ownership — it's what you'll find in every SPG product.

Area	Pages
Drive-Thru	38-41
Food Prep	30-35, 45, 54-61
Bakery	45, 46, 49, 54, 56
Freezer/Cooler	12-29, 49, 51
Dry Storage	12-23, 50-53, 65
Dish	46, 58, 59
Material Handling/Janitorial	42, 47, 66, 67
Specialty	36, 37, 55
Food Transport/Delivery	42-46, 48-51
Front Counter	55, 62, 64, 65

How to choose shelving



The right shelving system will provide you with the perfect combination of performance, features, benefits, longevity and efficiency. Following is a short primer on how to select and customize a shelving system that will fulfill your needs and provide your business with the lowest cost of ownership. When choosing shelving, consider:

Type of Material: SPG manufactures shelving in a wide range of material. Each has its own unique advantages: including wire, stainless steel, steel, aluminum, and plastic.

Wire: Strong, economical shelving systems for a wide range of environments

Stainless Steel: Natural corrosion resistance and strength for both dry storage and harsh high-moisture environments

Steel: Heavy-duty — with a variety of coatings for every area

Aluminum: Strong, lightweight and never rusts — it’s the perfect solution for caustic applications and harsh environments. And it’s the ideal material for both hot and cold environments

Plastic: Durable, rust-free and easy to clean — an economical solution for cooler/freezer use, as well as dry storage

The environment. Cooler and freezer applications require corrosion prevention — aluminum, stainless steel and plastic are naturally rust resistant. However, SPG has special finishes for our wire shelving that provide a surface that’s both extremely durable and rust resistant. All SPG shelving will perform excellently in dry environments — and all are NSF approved.

Finishes	Description
Plating Plus™	A 3-step process that includes: 1. Zinc plating 2. Rust-inhibiting chromate seal 3. Clear lacquer NSF approved
Contender Grey™	Dark Grey All SPG proprietary polymer coatings have 3-step process over plating quality steel wire:
Polygard®(Blue)	Blue 1. Zinc plating
Grey Bond®	Light Grey 2. Rust inhibiting chromate seal
Gold Bond®	Gold 3. Electrostatically applied baked-on antimicrobial polymer coating
All are NSF approved for food and splash zones	
Stainless Steel	An electro-polishing treatment is applied to surface of 300 Series Stainless Steel. NSF approved for all environments.
Aluminum	Lightweight and never rusts. NSF approved for all environments.



The space that you can dedicate to storage. If space is limited, you'll want a space-saving solution. Cantilever shelving is an excellent choice because it has no front uprights, so you'll get maximum, uninterrupted space. Shelves that can be easily repositioned can help eliminate wasted space. In coolers and freezers, our Mod-A-Flex®, Freestyle® and Kelmax shelving systems offer built-in and freestanding solutions that can dramatically increase capacity and operational efficiency. High-density and Ultra-density systems provide the ultimate in storage efficiency by minimizing and eliminating wasted aisle space.

Capacity. If you're storing heavy, high-density products like containers of liquids, kitchen equipment or sacks of produce, you'll need stronger shelving units.

Accessibility. Shelving should facilitate access to items that are stocked and restocked on a regular basis. With SPG cantilever shelving, there are no front posts to obstruct reach. And the marine waterfall edge on our ISS™ shelving makes loading and unloading fast, easy and secure.

Future storage needs. To allow for future expansion, choose an SPG scalable system — those with add-on kits that share an upright with the existing unit. This forms a single, structurally strong and continuous unit, and saves space to maximize storage capacity and reduces capital costs.

Additional factors.

Easily removable shelves help your staff clean more thoroughly and more quickly.

A wide selection of available accessories help you maximize shelf utility and staff efficiency.

The color of your shelving can coordinate with your decor and promote your brand identity.

Keep capacity, operational and adaptability efficiencies in mind to optimize your return on investment and maintain lowest cost of ownership.

No matter what your storage needs, SPG has the solution that will help you get more from your shelving investment. Contact your SPG representative today.

	ISS Contender Wire	ISS Wire	AMCO Wire	Kelmax Aluminum	Kelmax Cantilever	AMCO Mod-A-Flex	Freestyle Cantilever	Plastic Plus Plastic	Plasteel Plastic	New Era Plastic
Area										
Cooler/Freezer	Available	Available	Available	✓	✓	✓	Available	Available	Available	Available
Dry Storage	✓	✓	✓	✓	✓	–	✓	✓	✓	✓
Food Prep Area	✓	✓	✓	✓	✓	–	✓	✓	✓	✓
Non-Food Storage	✓	✓	✓	✓	✓	–	–	✓	✓	✓
High Density Storage	–	✓	✓	–	–	–	–	–	–	–
Shelf Weight Capacity										
	800 lbs. ¹	1250 lbs ²	1000 lbs ¹	2800 lbs ³	1500 lbs ⁴	400 lbs	600-1200 lbs	1000 lbs ¹	1000 lbs ¹	1000 lbs ¹
Available Finishes										
	C, CG	CP, E, Y	CP, PG, SS	AL	AL	GR	E			

Finishes: PG - Polygard C/CP - Plating Plus E - Grey Bond Y - Gold Bond CG - Contender Grey SS - Stainless Steel AL - Aluminum GR - Grey Epoxy
¹ 48-in shelf ² 60-in shelf ³ Per unit ⁴ Per shelf (Channel or Tubular)

AMCO® SHELVING

You'll find amazing strength in our numbers.

Compared to conventional wire shelving, the AMCO II® square-post system uses 27% more metal in our posts...our shelf wire averages 50% greater thickness...our welds are larger and stronger — the design of AMCO II® may be unique, but the commitment to quality is all SPG.



AMCO II® Shelving

- Unique square post design uses 27% more steel for greater strength and durability than typical round post systems
- Frame is 12-ga. solid steel
- Solid 2-1/8" robotic welds provide more stability than the two spot welds used on round post systems
- Shelf wire averages 50% thicker than other systems providing greater shelf capacity and strength
- Shelves come in 5 widths and 8 lengths
- Shelves up to 48" long support up to 1,000 lbs. (450 kg)
- Shelves are available in wire (standard, extra-wide, slanted and inverted with ledge) — plus heavy-duty, 18-ga. solid stainless steel, and plastic (Plasteel® and Plastic Plus®)
- Assembly is fast and easy with a one-piece shelf installation adapter
- Posts are notched on 2" centers to assure perfect shelf alignment every time
- Shelves have solid edges instead of truss edges, making them easier to clean and label

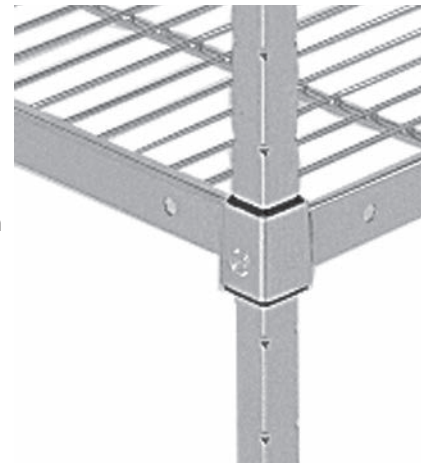

AMCO II® Starter Unit Kits

- Kits come with 4 posts and 4 or 5 shelves.
- Kits are available in 18" and 24" widths, and 64", 72" and 84" heights
- Select finish and add appropriate suffix to model number (see chart)

Finish	Use Suffix
Plating Plus™	CP
Polygard® (Blue)	PG
Stainless Steel	SS



For the complete line of AMCO® products, scan here to see our catalog



4-Tier 72-Inch Tall Starter Kits

Model No.	W x L x H (In)	Weight (Lbs.)
18-in. Wide Shelves		
1298	18 x 36 x 72	64
1300	18 x 48 x 72	80
1302	18 x 60 x 72	92
24-in. Wide Shelves		
1314	24 x 36 x 72	74
1316	24 x 48 x 72	94
1318	24 x 60 x 72	112

5-Tier 84-Inch Tall Starter Kits

Model No.	W x L x H (In)	Weight (Lbs.)
18-in. Wide Shelves		
2458	18 x 36 x 84	66
2460	18 x 48 x 84	86
2462	18 x 60 x 84	101
24-in. Wide Shelves		
1474	24 x 36 x 84	90
1476	24 x 48 x 84	115
1478	24 x 60 x 84	137

AMCO II® Add-On Kits

- Economical storage — provides plenty of strength for most applications
- Add-On units can be added to Starter Units to extend the shelf run, either continuing in a straight line or turning a corner at 90 degrees
- Kits come with 2 posts, 4 or 5 shelves and 2 add-on clips for each shelf (Posts and shelves shipped in separate cartons)
- Choose finish from chart on P. 12 — add suffix to model number

AMCO® 4-Tier 72-Inch Tall Add-On Kits

Model No.	W x L x H (In)	Weight (Lbs.)
18-in. Wide Shelves		
2298	18 x 36 x 72	54
2300	18 x 48 x 72	70
2302	18 x 60 x 72	82
24-in. Wide Shelves		
2314	24 x 36 x 72	64
2316	24 x 48 x 72	84
2318	24 x 60 x 72	102



SPG's foodservice products are all manufactured to meet NSF standards. For specific items, visit www.nsf.org



AMCO® 5-Tier 84-Inch Tall Add-On Kits

Model No.	W x L x H (In)	Weight (Lbs.)
18-in. Wide Shelves		
2458	18 x 36 x 84	66
2460	18 x 48 x 84	86
2462	18 x 60 x 84	101
24-in. Wide Shelves		
1474	24 x 36 x 84	90
1476	24 x 48 x 84	115
1478	24 x 60 x 84	137

Additional sizes and customized shelving solutions available — call the factory or your SPG rep for information.

AMCO II® Posts

Model No.	Height (In)	Height (mm)	Weight (Lbs.)	Weight (Kg.)
For Stationary Units				
P64	64	1625	4.5	2
P72	72	1830	5	2
P84	84	2130	5.5	2.5
For use with stem casters*				
PC64	64	1220	4.5	2
PC72	72	1370	5	2
PC84	84	1525	5.5	2.5

*Go Mobile - order Stem caster on page 80

AMCO II® Shelves

Model No.	W x L (In)	W x L (mm)	Weight (Lbs.)	Weight (Kg.)
A1836	18 x 36	455 x 915	11	5
A1848	18 x 48	455 x 1220	15	7
A1860	18 x 60	455 x 1525	18	8
A2436	24 x 36	610 x 915	13.5	6
A2448	24 x 48	610 x 1220	18.5	8
A2460	24 x 60	610 x 1525	23	10

Essentials By AMCO® Kits

- The ideal shelving for lighter load applications (up to 600 lbs. per shelf)
- Assembles easily in minutes
- Starter units consist of 4 shelves and 4 split posts
- Add-On units consist of 4 shelves, 2 split posts and 2 add-on clips for each shelf
- For dry storage only



Starter Unit Model No.	Color	W x L x H (In)	Weight (Lbs.)
B183672BK	Black	18 x 36 x 72	53
B183672GR	Grey	18 x 36 x 72	53
B184872BK	Black	18 x 48 x 72	60
B184872GR	Grey	18 x 48 x 72	60
Add-On Unit Model No.	Color	W x L x H (In)	Weight (Lbs.)
BA183672BK	Black	18 x 36 x 72	47
BA183672GR	Grey	18 x 36 x 72	47
BA184872BK	Black	18 x 48 x 72	54
BA184872GR	Grey	18 x 48 x 72	54

ISS™ SHELVING

Our most popular shelving for a lot of excellent reasons.

Versatility, innovation, strength — ISS™ brings it all together in a durable line of wire shelving that is both easy-to-assemble and competitively priced. So it's no wonder you'll find ISS™ shelving and accessories contributing to the efficiency and profitability of so many foodservice operations.



ISS™ Shelving

- Durable round post system is interchangeable with other manufacturers' shelving products
- Ideal for most any environment
- Shelves up to 60" long are rated to support 1,250 lbs. of uniformly distributed static weight
- Shelves feature extra trusses for a higher load rating, less deflection and the ability to use longer shelves
- Posts are numbered on 1" increments to speed assembly and ensure more precise shelf alignment
- Our one-piece hinged Sure-Lock™ coupler makes assembly easy and improves stability
- The marine waterfall shelf edge allows easy loading and unloading
- Shelves are available in wire (standard, wide-body, and inverted), dunnage, Series 300 solid stainless steel and plastic
- Four finishes are available — plus designer colors (See finishes on pg 15)



Starter Unit Convenience Packs

- Convenient 4-shelf unit packed in one carton
- Each carton has 4 shelves and four 2-piece split posts to make one 70" post
- Cartons take up minimal warehouse space
- One carton each saves on shipping costs and tracking time
- Ideal for immediate storage needs
- Available in four sizes and two finishes, Gold Bond® (Y) and Plating Plus (C) add finish suffix to model number

Model No.	W x L x H		Weight	
	(in.)	(mm)	(Lbs.)	(Kg)
1836PK	18 x 36 x 70	457 x 914 x 1778	49	22
1848PK	18 x 48 x 70	457 x 1219 x 1778	66.5	30
2436PK	24 x 36 x 70	610 x 914 x 1778	62	28
2448PK	24 x 48 x 70	610 x 1219 x 1778	78.5	35

To order, add finish suffix to model number



SPG's foodservice products are all manufactured to meet NSF standards. For specific items, visit www.nsf.org

Starter Unit Kits

- Starter unit kits consist of four posts and four or five shelves
- Kits are available in:
 - 2 shelf widths (18" and 24")
 - 3 shelf lengths (36", 48" and 60")
 - 3 heights (62-3/4", 74-3/4" and 86-3/4")

ISS™ 4-Tier 74-Inch Tall Starter Kits

Model No.	W x L x H (In)	Weight (Lbs.)
18-in. Wide Shelves		
S3347	18 x 36 x 75	61
S3547	18 x 48 x 75	73
S3747	18 x 60 x 75	83
24-in. Wide Shelves		
S5347	24 x 36 x 75	69
S5547	24 x 48 x 75	85
S5747	24 x 60 x 73	99

ISS™ 4-Tier 74-Inch Tall Add-On Kits

Model No.	W x L x H (In)	Weight (Lbs.)
18-in. Wide Shelves		
A3347	18 x 36 x 75	52.5
A3547	18 x 48 x 75	64.5
A3747	18 x 60 x 75	74.5
24-in. Wide Shelves		
A5347	24 x 36 x 75	60.5
A5547	24 x 48 x 75	76.5
A5747	24 x 60 x 75	90.5

ISS™ 5-Tier 86-Inch Tall Starter Kits

Model No.	W x L x H (In)	Weight (Lbs.)
18-in. Wide Shelves		
S3358	18 x 36 x 87	74
S3558	18 x 48 x 87	89
S3758	18 x 60 x 87	101.5
24-in. Wide Shelves		
S5358	24 x 36 x 87	84
S5558	24 x 48 x 87	104
S5758	24 x 60 x 87	121.5

ISS™ 5-Tier 86-Inch Tall Add-On Kits

Model No.	W x L x H (In)	Weight (Lbs.)
18-in. Wide Shelves		
A3358	18 x 36 x 87	72
A3558	18 x 48 x 87	87
A3758	18 x 60 x 87	99.5
24-in. Wide Shelves		
A5358	24 x 36 x 87	82
A5558	24 x 48 x 87	102
A5758	24 x 60 x 87	119.5

ISS™ Wire Shelves

Model No.	W x L (In)	W x L (mm)	Weight (Lbs.)	Weight (Kg)
14-in. Wide Shelves				
1436	14 x 36	356 x 914	9	4
1448	14 x 48	356 x 1219	11.5	5
1460	14 x 60	356 x 1524	15	7
18-in. Wide Shelves				
1836	18 x 36	457 x 914	11	5
1848	18 x 48	457 x 1219	14	6
1860	18 x 60	457 x 1524	16.5	7.5
24-in. Wide Shelves				
2436	24 x 36	610 x 914	13	6
2448	24 x 48	610 x 1219	17	8
2460	24 x 60	610 x 1524	20.5	10

ISS™ Posts

Model No.	Height (In)	Height (mm)	Weight (Lbs.)	Weight (Kg)
Digital Posts® For Stationary Shelving Units				
P74	75	1899	4	2
P86	87	2203	5	2
Digital Posts® For Use With Stem Casters				
P74N	75	1899	4	2
P86N	87	2203	5	2

SPG offers a full complement of shelving accessories — see page 68



Select finish and add appropriate suffix to model number

Finish	Use Suffix
Plating Plus™	C
Grey Bond®	E
Gold Bond®	Y
Stainless Steel	S

Colors (minimum order required)	
Black	ESB
Red	ESR

SMARTshelf™ SHELVING SYSTEM

Store Merchandising and Retail trade Shelf System

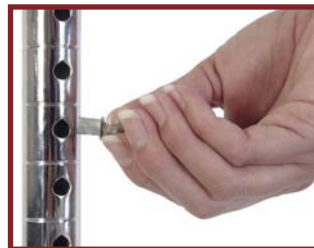

STANDARD FEATURES & BENEFITS

- The patented SMARTshelf™ shelving system is easy to assemble - no tools required
- The distance between shelves can be adjusted easily on 1" increments by simply moving the self-aligning support hooks
- Posts will accommodate both adjustable and fixed shelving
- The SMARTshelf™ system has a durable bright plated finish; optional colors available upon request
- Each shelf supports up to 300 lbs.
- Multiple shelf sizes available

STANDARD SHELVES AND POSTS

Shelves		Posts
Length	Width	Height
24"	14"	34"
30"	18"	54"
36"	21"	62"
42"	24"	74"
48"	—	86"
54"	—	—
60"	—	—

ISS CONTENDER™ SHELVING High-performance. Great value.

With our ISS Contender™ line, SPG has driven down the cost of wire shelving without sacrificing performance. ISS Contender™ offers impressive strength and capacity for general applications, corrosion resistance for all environments, ease of assembly — and just about everything you would expect to find on higher cost shelving.



- ISS Contender™ round post shelving is a strong, economical solution for both dry and refrigerated storage needs
- Available with Plating Plus™ finish for display and dry environments — or Contender Grey™ Epoxy finish which is warranted for seven years against naturally occurring corrosion in high-moisture, high-humidity environments
- Each 48" shelf is rated to support up to 800 lbs. (363 kgs) of uniformly distributed static load weight — longer shelves can support up to 600 lbs. (272 kgs)
- Assembles in minutes without tools or hardware
- Shelves are installed on the posts in 1" (25mm) increments — and can be changed easily as storage needs change

See our line of ISS Contender™ accessories on page 76.



Shelving Kit Convenience Packs

- Four shelves and four 70" split posts
- Available in Plating Plus™ or Contender Grey™ Epoxy finishes

Model No. Plating Plus™	Model No. Contender Grey™ Epoxy	W x L x H		Weight	
		(In.)	(mm.)	(In.)	(mm.)
IC1836KITC	IC1836KITCG	18 x 36 x 70	457 x 914 x 1778	54	24.5
IC1848KITC	IC1848KITCG	18 x 48 x 70	457 x 1219 x 1778	64	29
IC1860KITC	IC1860KITCG	18 x 60 x 70	457 x 1524 x 1778	84	38
IC2436KITC	IC2436KITCG	24 x 36 x 70	610 x 914 x 1778	68	31
IC2448KITC	IC2448KITCG	24 x 48 x 70	610 x 1219 x 1778	70	32
IC2460KITC	IC2460KITCG	24 x 60 x 70	610 x 1524 x 1778	92	42



SPG's foodservice products are all manufactured to meet NSF standards. For specific items, visit www.nsf.org

ISS Contender™ Wire Shelves

Model No.	W x L (in.) (mm)	Weight (Lbs.) (Kg)
18-in. Wide Shelves		
IC1836	18 x 36 457 x 914	9.5 4
IC1848	18 x 48 457 x 1219	12 5
IC1860	18 x 60 457 x 1524	17 8
24-in. Wide Shelves		
IC2436	24 x 36 610 x 914	13 6
IC2448	24 x 48 610 x 1219	16 7
IC2460	24 x 60 610 x 1524	21 9.5

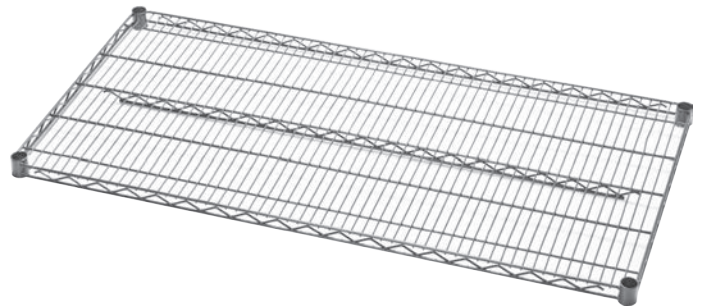

Add finish suffix to model number
 ISS Contender™ shelves are available:
 In 14", 18", 21" and 24" widths
 In 24", 30", 36", 42", 48", 54", 60" and 72" lengths
 To order other sizes: use MA + shelf width + shelf length +
 finish suffix (Example: MA1824C)

ISS Contender™ Posts For Stationary Use

Model No.	Height (In) (mm)	Weight (Lbs.) (Kg)
IC072	72 1829	4 2
IC084	84 2134	5 2

Add finish suffix to model number
 ISS Contender™ posts are also available:
 In 7", 34", 54" and 64" heights



ISS Contender™ Posts With No Foot For Use With Stem Casters

Model No.	Height (In) (mm)	Weight (Lbs.) (Kg)
IC064NF	64 1626	3.5 2
IC072NF	72 1829	4 2
IC084NF	84 2134	5 2

Add finish suffix to model number
 ISS Contender™ posts are also available:
 In 7", 34", 54" and 64" heights

Finish	Use Suffix
Plating Plus™ finish for display and dry environment applications — 1-Year Warranty against corrosion in dry environments	C
Contender Grey™ finish for moist/humid environments — 7-Year Warranty under normal use against naturally occurring corrosion	CG



ISS™ NEW ERA™ SHELVING

The same type of quality, durability and performance you'll find in our popular ISS™ wire shelving in a plastic solution — it's one more choice SPG offers, and one more reason to choose SPG as your single source for storage solutions.



- Corrosion free shelves — heavy-duty epoxy coated steel frames and grey polypropylene plastic removable panels
- Antimicrobial agent protects the shelf finishes from bacteria, mold, mildew and fungi that cause odors, stains and product degeneration — keeping shelving cleaner in between cleanings*
- Available in solid and vented styles
- Sectional panels are easy to remove and clean
- Shelves can be used with ISS™ posts and shelving components — stainless steel posts recommended
- No tools or hardware required
- Can be used in all environments from -20°F (-29°C) to 190°F (88°C)
- Load capacity of 1,000 lbs. (455kgs) per shelf of uniformly distributed static weight

* This product does not protect users or others against bacteria, viruses, germs or other disease organisms. It is for the protection of the product only. The antimicrobial product should always be thoroughly cleaned after each use.

Check out our complete line of ISS™ shelving accessories on pages 72 - 75.



SPG's foodservice products are all manufactured to meet NSF standards. For specific items, visit www.nsf.org



New Era™ Vented Shelves

Model No.	W x L (in.)	(mm)	Weight (Lbs.) (Kg)	
18-in. Wide Shelves				
LPS1836V	18 x 36	457 x 914	12	5
LPS1848V	18 x 48	457 x 1219	15.5	7
LPS1860V	18 x 60	457 x 1524	19.5	9
24-in. Wide Shelves				
LPS2436V	24 x 36	610 x 914	14	6
LPS2448V	24 x 48	610 x 1219	18	8
LPS2460V	24 x 60	610 x 1524	23	10

New Era™ Shelves are available:
 In 18", 21" and 24" widths
 In 24", 30", 36", 42", 48", 54" and 60" lengths



New Era™ Solid Shelves

Model No.	W x L (in.)	(mm)	Weight (Lbs.) (Kg)	
18-in. Wide Shelves				
LPS1836S	18 x 36	457 x 914	12	5
LPS1848S	18 x 48	457 x 1219	15.5	7
LPS1860S	18 x 60	457 x 1524	19.5	9
24-in. Wide Shelves				
LPS2436S	24 x 36	610 x 914	14	6
LPS2448S	24 x 48	610 x 1219	18	8
LPS2460S	24 x 60	610 x 1524	23	10

New Era™ Shelves are available:
 In 18", 21" and 24" widths
 In 24", 30", 36", 42", 48", 54" and 60" lengths



New Era™ Posts

Model No. Stationary Posts	Model No. Mobile Posts	Height (in.)	Height (mm)	Weight (Lbs.)	Weight (Kg)
Stainless Steel Posts					
P74S	P74NS	75	1899	4	2
P86S	P86NS	87	2203	5	2
Steel Posts With Grey Bond® Finish					
P74E	P74NE	75	1899	4	2
P86E	P86NE	87	2203	5	2

Stainless Steel and Grey Bond® are the optimum finishes for use with New Era™ Shelves

New Era™ Posts are also available in:
 8", 14", 34", 54" and 62" heights



AMCO® PLASTIC PLUS® & PLASTEEL® SHELVING

Two great options, one reliable source.

AMCO® Plastic Plus™ solid polypropylene plastic removable panels or Plasteel® steel-reinforced plastic shelves — both offer durable performance in any environment, are compatible with AMCO® accessories and deliver the quality and value that you expect from SPG.



AMCO® Plastic Plus® Shelving

- Grey polypropylene plastic removable panels easily snap onto heavy duty epoxy coated frames
- Sectional panels can be easily removed from frames for cleaning — no tools or hardware required
- An antimicrobial agent protects the finish from bacteria, mold, mildew and fungi that cause odors, stains and product degradation*
- For all environments from -20°F (-29°C) to 190°F (88°C)
- Strength rated to support 1,000 lbs. (455kg) of uniformly loaded static weight per shelf
- Fits standard AMCO® square posts and is compatible with other AMCO® shelving products
- Stainless steel posts recommended for a rust-free solution

* This product does not protect users or others against bacteria, viruses, germs or other disease organisms. It is for the protection of the product only. This antimicrobial product should always be thoroughly cleaned after each use.



AMCO® Plastic Plus® Vented Shelves

Model No.	W x L (in.)	W x L (mm)	Weight (Lbs.) (Kg)	
18-in. Wide Shelves				
PP1836V	17 x 36	455 x 915	12	5
PP1848V	17 x 48	455 x 1220	15.5	7
PP1860V	17 x 60	455 x 1525	19.5	9
24-in. Wide Shelves				
PP2436V	23 x 36	610 x 915	14	6
PP2448V	23 x 48	610 x 1220	18	8
PP2460V	23 x 60	610 x 1525	23	10



Plastic Plus® shelves are available:

In 18" and 24" widths

In 24", 30", 36", 42", 48", 54" and 60" lengths

See our line of shelving accessories starting on page 68.

Plastic Plus® Solid Shelves

Model No.	W x L (in.)	(mm)	Weight (Lbs.)	(Kg)
18-in. Wide Shelves				
PP1836S	17 x 36	455 x 915	12	5
PP1848S	17 x 48	455 x 1220	15.5	7
PP1860S	17 x 60	455 x 1525	19.5	9
24-in. Wide Shelves				
PP2436S	23 x 36	610 x 915	14	6
PP2448S	23 x 48	610 x 1220	18	8
PP2460S	23 x 60	610 x 1525	23	10



Plastic Plus® shelves are available:
 In 18" and 24" widths
 In 24", 30", 36", 42", 48", 54" and 60" lengths

AMCO II® Plasteel® Shelves

- Steel-reinforced plastic shelves support 1,000 lbs. each
- Available in solid or vented style — solid style has raised edge to contain liquid spills
- Grey high-impact structural foam plastic
- May be used with all other styles of Amco II® shelves
- Solid style accepted by the United States Department of Agriculture for direct food contact
- Stainless steel post recommended since it never rusts

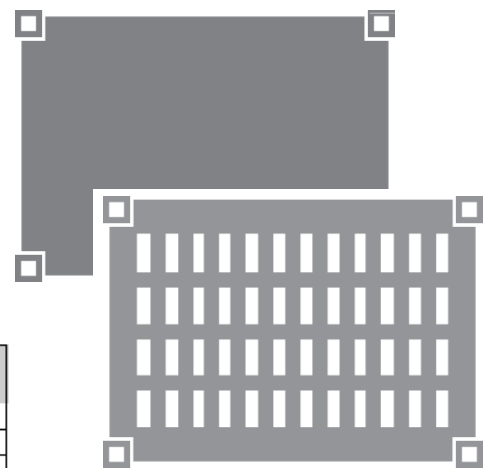

Vented Shelf Model No.	Solid Shelf Model No.	W x L (in.)	(mm)	Weight (Lbs.)	(Kg)
PS1836V	PS1836S	17 x 36.5	476 x 927	16	7
PS1842V	PS1842S	17 x 42.5	476 x 1080	17	8
PS1848V	PS1848S	17 x 48.5	476 x 1232	21	9.5
PS1860V	PS1860S	17 x 60.5	476 x 1537	29	13
PS2436V	PS2436S	25 x 36.5	629 x 927	19	9
PS2442V	PS2442S	25 x 42.5	629 x 1080	21	9.5
PS2448V	PS2448S	25 x 48.5	629 x 1232	25	11
PS2460V	PS2460S	25 x 60.5	629 x 1537	33	15

AMCO® Posts For Plastic Plus® and Plasteel® Shelving

Model No.	Height (in.)	(mm)	Weight (Lbs.)	(Kg)
Stationary Stainless Steel Posts				
P72SS	72	1830	5	2
P84SS	84	2130	5.5	2.5
Stationary Steel Posts With Grey Bond® Finish				
P72GR	72	1830	5	2
P84GR	84	2130	5.5	2.5
Mobile Stainless Steel Posts				
PC72SS	72	1830	5	2
PC84SS	84	2130	5.5	2.5
Mobile Steel Posts With Grey Bond® Finish				
PC72GR	72	1830	5	2
PC84GR	84	2130	5.5	2.5



- 16-ga. (.065") 1" O.D. square tube construction
- Notched every 2" on each corner
- Includes a top polypropylene post cap
- Stationary posts have a nylon housing on the bottom for a steel leveler



SPG's foodservice products are all manufactured to meet NSF standards. For specific items, visit www.nsf.org

AMCO® posts are available in:
 8", 14", 34", 54", 64", 72" and 84" heights
 Stainless steel (SS), Grey Bond® (GR) or Polygard® (PG) finishes

KELMAX SHELVING

All the advantages of aluminum,
all the quality of SPG.

Synonymous with quality aluminum products, our Kelmax line offers a wide range of choices that are rustproof, lightweight, support up to 1,500 lbs. per shelf and excel in any environment and in any application.



- Aluminum construction offers higher load ratings — so larger loads can be supported across a longer span of shelving
- Aluminum shelving is ideal in hot or caustic applications that might damage the coating of wire shelving
- Kelmax shelving is warranted to be free from manufacturing defects for five years

Kelmax Fixed Shelving Units

- All welded aluminum shelving ships set up
- Overall height is 60" for 2 and 3-shelf units and 72" for 4-shelf unit
- Mitered top for extra strength
- Clearance between shelves:
Two-shelf unit: 48.5"
Three-shelf unit: 22.5"
Four-shelf unit: 18.5"
- Choose from 4 types of shelves



SPG's foodservice products are all manufactured to meet NSF standards. For specific items, visit www.nsf.org



Need to maximize usable space in coolers and freezers? See Kelmax Adjustable Cantilever shelving on page 28.

Kelmax 4-Tier Shelving Units

Tubular Shelf Model No.	T-Bar Shelf Model No.	Channel Shelf Model No.	Solid Shelf Model No.	L x W x H		Weight	
				(in.)	(mm)	(Lbs.)	(Kg)
20- in. Wide Shelves							
4H0571	4H4083	4H2414	4H6898	36 x 20 x 72	914 x 508 x 1829	48	22
4H0594	4H4082	4H0490	4H6900	48 x 20 x 72	1219 x 508 x 1829	59	27
4H0610	4H0646	4H0525	4H6902	60 x 20 x 72	1524 x 508 x 1829	70	32
24- in. Wide Shelves							
4H0578	4H0641	4H0468	4H6899	36 x 24 x 72	914 x 610 x 1829	54	24
4H0602	4H0645	4H0506	4H6901	48 x 24 x 72	1219 x 610 x 1829	66	30
4H0618	4H0649	4H0540	4H6541	60 x 24 x 72	1524 x 610 x 1829	79	36

Also available in 2-tier and 3 tier units

Kelmax Aluminum Adjustable Shelving

- Create a custom aluminum shelving solution with a choice of four different shelving types (see below)
- Load capacities from 900 lbs. to 2,100 lbs. per shelf
- Shelves are adjustable and interchangeable in the same width and length

Solid Shelf Model No.	Tubular Shelf Model No.	T-Bar Shelf Model No.	Channel Shelf Model No.	(in.)	L x W (mm)	Weight (Lbs.) (Kg)	
18-in. Wide Shelves							
4H0208	4H0177	4H0246	4H0082	36 x 18	914 x 457	8	4
4H0210	4H0179	4H0248	4H0084	48 x 18	1219 x 457	11	5
4H0212	4H0181	4H0250	4H0086	60 x 18	1524 x 457	13	6
24-in. Wide Shelves							
4H0226	4H0191	4H0260	4H0097	36 x 24	914 x 610	9	4
4H0228	4H0193	4H0262	4H0099	48 x 24	1219 x 610	13	6
4H0230	4H0195	4H0264	4H0102	60 x 24	1524 x 610	15	7

Also available in 20" and 30" shelf widths

Shelf Selection Guide

Which shelves are right for you? Use this quick reference to help guide your selection:

Solid Shelves: A solid all-around choice — ideal for storage of small items and to contain spills.

Tubular Shelves: Ideal for the storage of cases or large boxes.

T-Bar Shelves: The extra vertical support you need when storing items perpendicularly.

Channel Shelves: Provide extra strength for large or small items, while allowing air circulation.



Solid Shelf



Tubular Shelf



T-Bar Shelf



Channel Shelf



Kelmax Posts

Model No.	Height (in.)	Height (mm)	Weight (Lbs.)	Weight (Kg)
4H0162	76	1930	4	2
4H0167	84	2134	5	2.5

Freestyle® CANTILEVER SHELVING — the ultimate in freestanding cooler/freezer storage.

In real-store tests, Freestyle® shelving systems increased usable storage surface space up to 68% in coolers and up to 60% in freezers — which makes Freestyle® a proven way to get more out of every square foot of your operation and every dollar of your shelving investment.



- Each shelf has a load-bearing capacity of 600 lbs. with a unit rating of 1,800 lbs. for cantilevered shelves and 1,000 lbs. capacity on the bottom shelf — for a total unit capacity of 2,800 lbs.
- No front uprights — so it offers greater accessibility to inventory
- Increases sq. ft. and cubic volume storage capacity in existing footprint
- Adjustable shelves on 2" increments for maximum flexibility — no tools required
- Unit is fully expandable side-to-side with Add-On unit — using common uprights with dual-side adjustment
- Durable heavy-duty steel construction
- Shelving available in 5 widths and 8 lengths
- Uprights available in 5 heights
- Shelves, uprights, and frame kits have a durable grey epoxy-based finish with advanced antimicrobial protective agent
- Complete assortment of accessories including hanger rails and shelf covers in wire and stainless steel



SPG's foodservice products are all manufactured to meet NSF standards. For specific items, visit www.nsf.org



Scan here to see our Freestyle® video

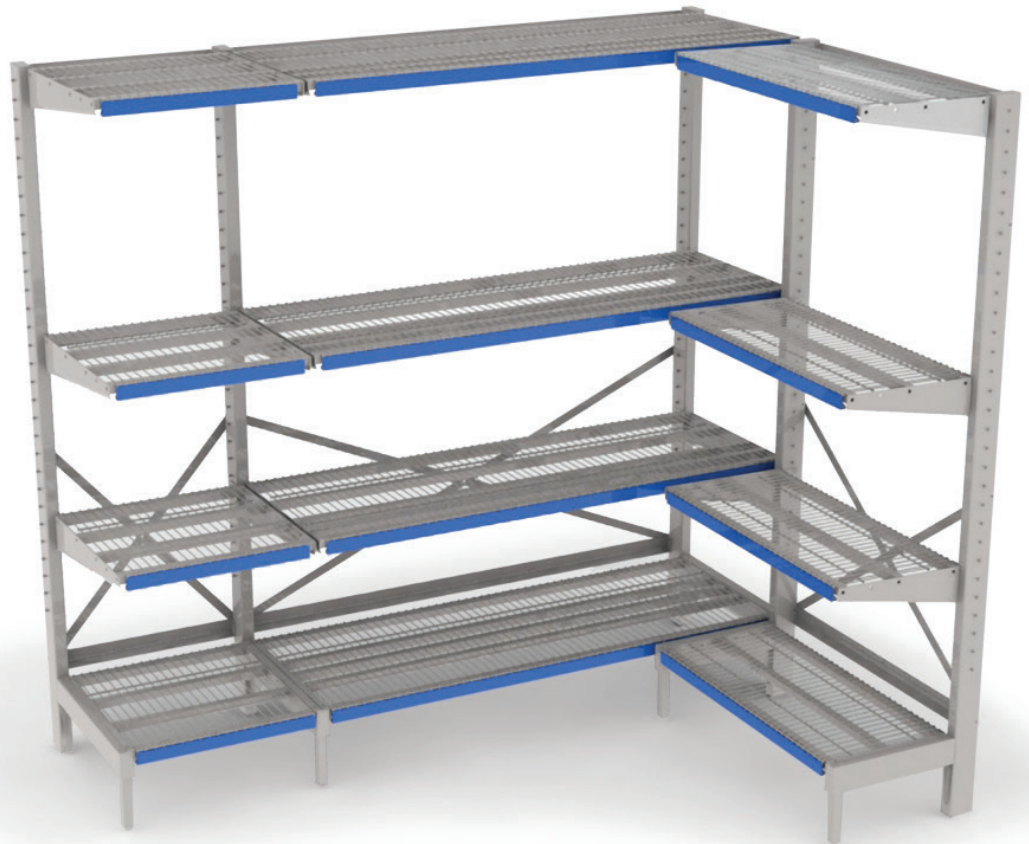

Freestyle® 4-Tier Starter Units

Includes: 1 starter frame kit, 3 standard shelves, 1 bottom shelf.
4 standard wire covers with label holders.

Model No.	W x L x H		Weight	
	(in.)	(mm)	(Lbs.)	(Kg)
FSMS741836E	18 x 36 x 74	457 x 914 x 1880	138	62
FSMS741848E	18 x 48 x 74	457 x 1219 x 1880	158	72
FSMS741860E	18 x 60 x 74	457 x 1534 x 1880	193	88
FSMS742436E	24 x 36 x 74	609 x 914 x 1880	160	72
FSMS742448E	24 x 36 x 74	609 x 1219 x 1880	185	84
FSMS742460E	24 x 36 x 74	609 x 1534 x 1880	211	96
FSMS861836E	18 x 36 x 86	457 x 914 x 2184	144	66
FSMS861848E	18 x 48 x 86	457 x 1219 x 2184	165	75
FSMS861860E	18 x 60 x 86	457 x 1534 x 2184	200	91
FSMS862436E	24 x 36 x 86	609 x 914 x 2184	166	75
FSMS862448E	24 x 48 x 86	609 x 1219 x 2184	191	87
FSMS862460E	24 x 60 x 86	609 x 1534 x 2184	217	98

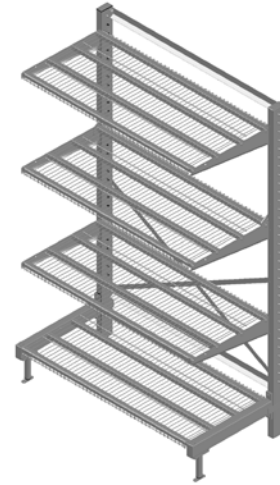

Freestyle® 4-Tier Add-On Units

Includes: 1 add-on frame kit, 3 standard shelves, 1 bottom shelf.
4 standard wire covers with label holders.

Model No.	W x L x H		Weight	
	(in.)	(mm)	(Lbs.)	(Kg)
FSMA741836E	18 x 36 x 74	457 x 914 x 1880	111	51
FSMA741848E	18 x 48 x 74	457 x 1219 x 1880	132	60
FSMA741860E	18 x 60 x 74	457 x 1534 x 1880	167	76
FSMA742436E	24 x 36 x 74	609 x 914 x 1880	132	60
FSMA742448E	24 x 48 x 74	609 x 1219 x 1880	158	72
FSMA742460E	24 x 60 x 74	609 x 1534 x 1880	183	83
FSMA861836E	18 x 36 x 86	457 x 914 x 2184	115	52
FSMA861848E	18 x 48 x 86	457 x 1219 x 2184	135	61
FSMA861860E	18 x 60 x 86	457 x 1534 x 2184	170	77
FSMA862436E	24 x 36 x 86	609 x 914 x 2184	136	62
FSMA862448E	24 x 48 x 86	609 x 1219 x 2184	161	73
FSMA862460E	24 x 60 x 86	609 x 1534 x 2184	187	85

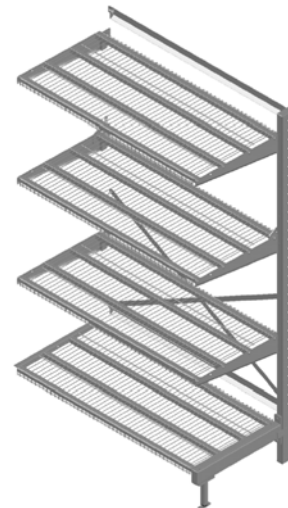

Freestyle® Reinforcement Brace

- Dramatically increases the load capacity of Freestyle® shelving:
 - by 25% on 30-in. shelves, from 600 lbs. to 800 lbs.
 - by 40% on shelves up to 24-in. deep, from 600 lbs. to 1,000 lbs.
- Provides the additional strength critical for the storage and display of heavy, high-density products
- Low-profile design and placement make it virtually invisible and will not interfere with shelf positioning
- Installation is fast, easy and requires no tools
- Significantly increases the life of your shelving
- Set includes 1 left and 1 right brace for shelf

Model No.	Weight(Lbs.)
FSRBESET	0.5

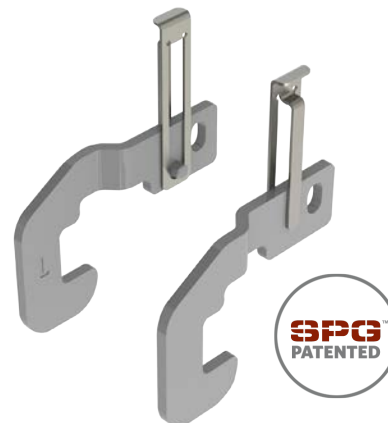

AMCO® MOD-A-FLEX® SHELVING

Get more out of your coolers & freezers

This unique, patented shelving system is supported from the walls or ceiling, eliminating front posts and increasing storage capacity by 30%. The Mod-A-Flex® system also features an impressive 400-lb. per shelf capacity, an antimicrobial grey-epoxy finish and all the features you need to store more and earn more.



Every detail of the Mod-A-Flex® system is designed to improve employee efficiency, productivity and speed of service — reducing labor and storage costs while contributing to overall operational results.

Mod-A-Flex® not only increases storage capacity up to 30% ... it also offers greater organization and higher visibility of stock... shelves can also be quickly and easily removed and repositioned...and because there are no posts, cleaning the floor is faster, easier and more thorough.

Mod-A-Flex® System

- Designed for walk-in coolers and freezers
- Ceiling mounted — no need to reinforce side walls
- Boosts capacity by up to 30% with the freedom to adjust shelves to the height of the product being stored
- No posts on the floor make cleaning easy
- Shelves can be removed without tools for cleaning
- Easy and fast adjustment of shelves; simply slide the shelf sideways to lift out of current location
- Antimicrobial grey epoxy coating for maximum cleanliness and moisture resistance



For more information, scan here for the AMCO® Mod-A-Flex® spec sheet



Mod-A-Flex® Shelves

Model No.	W x L		Weight	
	(In)	(mm)	(Lbs.)	(Kg)
MX1824GR	18 x 22.5	451 x 572	9	4
MX1836GR	18 x 34.5	451 x 876	12	5
MX1848GR	18 x 46.5	451 x 1181	15	7
MX2124GR	21 x 22.5	527 x 572	12	5
MX2136GR	21 x 34.5	527 x 876	17	8
MX2148GR	21 x 46.5	527 x 1181	21	9.5

Mod-A-Flex® Shelves are available:
 In 11-3/4", 17-3/4" and 20-3/4" widths
 In 22-1/2", 28-1/2", 34-1/2", 40-1/2" and 46-1/2" lengths
 Nominal shelf widths are: 12", 18" and 21"
 Nominal shelf lengths are: 24", 30", 36", 42" and 48"
 NOTE: Two support arms included with each shelf



Mod-A-Flex® Standards For Cooler Freezer

Model No.	Height		Weight	
	(In)	(mm)	(Lbs.)	(Kg)
MX68GR	68	1727	9	4
MX72GR	72	1829	12	5
MX81GR	81	2057	15	6

Mod-A-Flex® Standards For Dry Environments

Model No.	Height		Weight	
	(In)	(mm)	(Lbs.)	(Kg)
MXD72GR	72	1829	11	5
MXD85GR	85	2159	13	6

Mod-A-Flex® Standards are available:
 In 24", 36", 40", 61" 68", 72", 81" and 85" heights for installation in coolers and freezers
 18", 36" and 85" for installation in dry environments
 With Extender Kits to increase installation height

The Mod-A-Flex® Secret

The patented secret to this postless system is that standards are securely suspended from the ceiling of the walk-in cooler. This provides the strength assurance that each shelf will support 400 lbs of static weight.

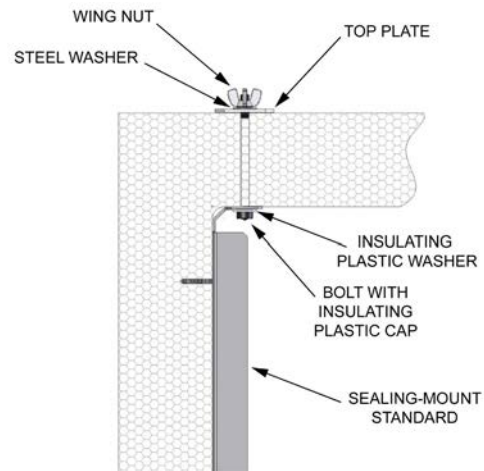

Turn the page to see Kelmax Adjustable Cantilever Shelving

KELMAX ADJUSTABLE Cantilever shelving

Extraordinary strength and space efficiency combined with easy stock access and exceptional corrosion resistance — they're the traits that elevate Kelmax above the competition and make our cantilever shelving the best choice for your cooler and freezer storage needs.



Kelmax Cantilever Shelving

- Made of heavy-gauge aluminum — which is strong, durable, lightweight and never rusts
- The cantilever system is ideal for increasing usable space in coolers and freezers — since there are no front posts, storage is maximized and access is much easier
- Aluminum construction offers higher load ratings — larger loads can be supported across a longer span of shelving
- Available with a choice of channel, tubular and solid shelving
- Aluminum shelving is ideal in hot or caustic applications that might damage the coating of wire shelving



Kelmax Cantilever Fixed Shelving Units

- Includes frame and 2 – 4 fixed shelves (20" or 24" depths)
- For safety, front legs do not extend past the bottom shelf
- Tubular bottom shelf is standard with all kits, and is easily removed without the use of tools for cleaning — all other shelves are fixed and not adjustable or removable
- Clearance between fixed shelves:
 - Two-shelf unit: 59"
 - Three-shelf unit: 28"
 - Four-shelf unit: 18"
- Channel and tubular shelves support 1500 lbs. per shelf — solid shelves support 900 lbs. per shelf
- Freestanding unit — does not require bolting to walls for support

Kelmax 4-Shelf Units

Channel Shelf Model No.	Tubular Shelf Model No.	Solid Shelf Model No.	(in.)	L x W x H (mm)	Weight (Lbs.)	Weight (Kg)
20-in. Wide Shelves						
4H0310	4H0370	4H0399	36 x 20 x 72	914 x 508 x 1829	68	31
4H0341	4H0381	4H0408	48 x 20 x 72	1219 x 508 x 1829	84	38
4H0362	4H0388	4H0413	60 x 20 x 72	1524 x 508 x 1829	97	44
24-in. Wide Shelves						
4H0317	4H0378	4H0403	36 x 24 x 72	914 x 610 x 1829	72	33
4H0351	4H0386	4H0411	48 x 24 x 72	1219 x 610 x 1829	92	41
4H0366	4H0395	4H0416	60 x 24 x 72	1524 x 610 x 1829	106	48

Also available in 2-tier and 3-tier units

Kelmax Cantilever Frames and Adjustable Shelves

- Tubular base dunnage shelf is standard, and easily removed without the use of tools for cleaning
- Up to 5 additional shelf positions — shelves can be added or removed without tools
- Available in two shelf depths: 20" and 24"
- Clearance between adjustable shelves is 10"
- Maximum load capacity per shelving unit is 2,800 lbs
- Frames and adjustable shelves sold separately



Kelmax Cantilever Frames

Model No.	L x W x H (in.)	L x W x H (mm)	Weight (Lbs.) (Kg)	
20-In Deep Shelving Frame				
4H4201	36 x 20 x 72	914 x 508 x 1829	49	22
4H4366	48 x 20 x 72	1219 x 508 x 1829	55	25
4H4482	60 x 20 x 72	1524 x 508 x 1829	61	27
24-In Deep Shelving Frame				
4H4501	36 x 24 x 72	914 x 610 x 1829	64	29
4H2977	48 x 24 x 72	1219 x 610 x 1829	75	31
4H4500	60 x 24 x 72	1524 x 610 x 1829	86	39

Kelmax Cantilever Shelves

Channel Shelf Model No.	Tubular Shelf Model No.	Solid Shelf Model No.	L x W (in.) (mm)		Weight (Lbs.) (Kg)	
20-in. Deep Shelves						
4H4202	4H4203	4H4450	36 x 20	914 x 508	10	4
4H4368	4H4439	4H4561	48 x 20	1219 x 508	12	5
4H5129	4H4568	4H4484	60 x 20	1524 x 508	14	6
24-in. Deep Shelves						
4H4713	4H4505	4H5132	36 x 24	914 x 610	11	5
4H2978	4H2979	4H4938	48 x 24	1219 x 610	13	6
4H4763	4H4504	4H5473	60 x 24	1524 x 610	15	7



SPG's foodservice products are all manufactured to meet NSF standards. For specific items, visit www.nsf.org

Kelmax Tubular Base Dunnage Shelf

Model No.	L x W (In.)	L x W (mm)	Weight (Lbs.) (Kg)	
20-Inch Deep Shelves				
4H4400	36 x 20	914 x 508	10	4
4H4367	48 x 20	1219 x 508	12	5
4H4483	60 x 20	1524 x 508	14	6
24-Inch Deep Shelves				
4H4509	36 x 24	914 x 610	11	5
4H4432	48 x 24	1219 x 610	13	6
4H4508	60 x 24	1524 x 610	15	7

How To Order

1. Choose frame size
2. Choose tubular base dunnage shelf that matches the frame size
3. Choose type of shelf (channel, tubular or solid) and the shelf size
4. Specify the number of shelves

See page 23 for more detailed images and descriptions of channel, tubular and solid shelving.

ISS™ WALL TRAX™ Wall-to-wall efficiency.

Minimize wasted time and motion of your kitchen staff — and increase productivity and service speed! Employing a channel and grid design, the ISS™ Wall Trax™ System ensures the ingredients, tools and utensils your kitchen staff needs are always within easy reach.

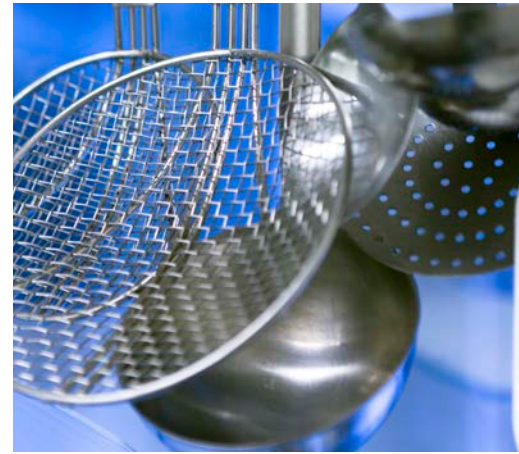

ISS™ Wall Trax™ is a complete wall mounted storage solution with specially engineered aluminum channel and grid system to increase efficiency and expand storage capacity.

- ISS™ Wall Trax™ channels and grids are easy to install
- Easily attach accessories without the need for tools or hardware
- All shelves can be moved by simply unhooking from grid or channel
- Available in three finishes, all corrosion-resistant, epoxy-based polymer coated: Grey Bond®, Gold Bond® and Polygard® (Blue)



Use this chart to select your finish

Finish	Use Suffix
Grey Bond®	E
Gold Bond®	Y
Polygard® (Blue)	PG



ISS™ Wall Trax™ Hooks

Model No.	Description	W x L x W (in.)	(mm)	Weight (Lbs.)	(Kg)
Hanging Hooks (Attach to Wall Trax channel or grid)					
HOOK24	24" hook w/seven 6" prongs	7 x 24 x 6.5	182 x 603 x 165	2	.8
HOOK12	12" hook w/four 6" prongs	7 x 12 x 6.5	182 x 305 x 165	1	.5
PHK	Pot hook				
Wall-mounted Hooks (Attach directly to wall)					
HOOK246R2	24" hook w/seven 6" prongs	6.5 x 24 x 7	182 x 603 x 165	2	.8
HOOK243R1	12" hook w/four 6" prongs	3.5 x 24 x 7	89 x 629 x 184	1	.5
HOOK20ADJ	20" hook w/seven 3" prongs	4 x 20 x 4.5	83 x 502 x 114	1.5	.7



Select finish - add suffix to model number

ISS™ Wall Trax™ Accessories

Model No.	Description	W x L x H (in.)	(mm)	Weight (Lbs.)	(Kg)
GRBTLHD	Bottle Holder	4 x 21 x 13	102 x 533 x 330	2	.1
GRSCOOP	Scoop Holder	5 x 10 x 6	127 x 254 x 150	3	.6
DISHHOLD	Monkey Dish Holder	4 x 21 x 17	102 x 533 x 432	24	11
PLATERK	Plate Rack	8 x 8 x 1	216 x 216 x 54	1.5	.7

Select finish — add suffix to model number. Additional sizes available



ISS™ Wall Trax™ Shelves

Model No.	W x L (in.)	W x L (mm)	Weight (Lbs.) (Kg)	
Flat Shelves				
GS1436	14 x 36	356 x 914	8	4
GS1448	14 x 48	356 x 1219	11	5
GS1836	18 x 36	457 x 914	9	4
GS1848	18 x 48	457 x 1219	13	6
Flat Shelves with Lip				
GSL1436	14 x 36	356 x 914	8	4
GSL1448	14 x 48	356 x 1219	11	5
GSL1836	18 x 36	457 x 914	9	4
GSL1848	18 x 48	457 x 1219	13	6
Slanted Shelves				
GSS1436	14 x 36	356 x 914	8	4
GSS1448	14 x 48	356 x 1219	11	5
GSS1836	18 x 36	457 x 914	9	4
GSS1848	18 x 48	457 x 1219	13	6

Select finish — add suffix to model number.



ISS™ Wall Trax™ Grid

- Mounts directly to wall — brackets included

Model No.	W x L (in.)	W x L (mm)	Weight (Lbs.) (Kg)	
GRWM2436	24 x 36	610 x 914	10	4.5
GRWM2448	24 x 48	610 x 1219	13	6
GRWM3636	36 x 36	914 x 914	15	7
GRWM3648	36 x 48	914 x 1219	19	9

Select finish — add suffix to model number.



ISS™ Wall Trax™ Offset Grid

- For use with channels

Model No.	W x L (in.)	W x L (mm)	Weight (Lbs.) (Kg)	
GRO2436	24 x 36	610 x 914	10	4.5
GRO2448	24 x 48	610 x 1219	13	6

ISS™ Wall Trax™ Baskets

Model No.	W x L x H (in.)	W x L x H (mm)	Weight (Lbs.) (Kg)	
GB12186	12 x 18 x 6	305 x 457 x 150	3	1
GB14183	14 x 18 x 3	355 x 457 x 76	3	1
GBSPNK	5 x 12 x 4	126 x 305 x 102	1	.5
GB12106	12 x 10 x 6	254 x 305 x 150	2.5	1

Select finish — add suffix to model number. Additional sizes available



ISS™ Wall Trax™ Channel

Model No.	W x L (in.)	W x L (mm)	Weight (Lbs.) (Kg)	
TRAX2A	4 x 24	102 x 610	3.5	1
TRAX4A	4 x 48	102 x 1219	7	3
TRAX8A	4 x 96	102 x 2438	14	6
TRAXSTOPS	Wall Trax™ Channel End Caps (1 ea.)			
TRAXTOGS	Wall Trax™ Toggle Fasteners			

For more information, scan here to see our Wall Trax™ spec sheet



WALL SHELVING

How to make the most of your space.

Only SPG offers you so many ways to transform that unused wall space above sinks, worktables and counters into valuable storage. Wall shelving from ISS™, AMCO®, Kelmax and Universal® all provide distinctive features and benefits — and all are available from a single source.



ISS™ Wall Shelving

- Choose from three ISS™ Wall Shelving products that support ISS™, AMCO® and ISS Contender™ cantilever shelves on catalog pages 13, 15 and 17.

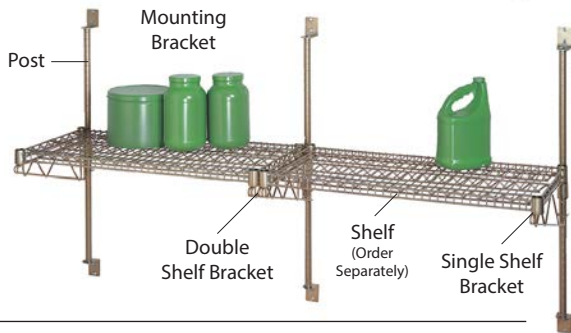

ISS™ Wall Mount Post Kit

- Posts attach directly to wall, shelves attach to posts with Sure-Lock™ couplers (included with shelves)
 - Each kit includes two posts and four post brackets
 - Recommended for shelves 14" and 18" wide and up to 48" long
 - Strength rated to 60 lbs. of evenly distributed static loaded
- Hardware for mounting the brackets to the wall not included

Model No.	Width		Weight	
	(in.)	(mm)	(Lbs.)	(Kg)
WMT14Y	14	356	3	1
WMT34Y	34	876	5	2

ISS™ Single & Double Shelf Brackets

- Order one single-shelf bracket for each end of shelf
- Order one double shelf bracket where shelves share a common post

Plating Plus™ Model No.	For Shelf Width		Weight	
	(in)	(mm)	(Lbs.)	(Kg)
Single Wall Mount Bracket				
PWS14C1	14	356	1.5	.7
PWS18C1	18	457	2	.9
PWS24C1	24	610	2.5	1.1
Double Wall Mount Bracket				
PWS14C2	14	356	3	1.4
PWS18C2	18	457	3.5	1.6
PWS24C2	24	610	4	1.8



Also available in Gold Bond® (Y) and Grey Bond® (E) finishes

ISS™ Wall Mount Posts

Plating Plus™ Model No.	Gold Bond® Model No.	Description	(in.)	(mm.)
PWMT14C	PWMT14Y	For 1 tier of shelves	14	356
PWMT34C	PWMT34Y	For 2 tiers of shelves	34	864

Also available in 54" and 62" heights for 3 or more shelves, Shelves ordered separately

How To Order

Step 1: Order Posts

- Posts can support one or more tiers of shelving
- For a continuous run of shelving, shelves share a middle post
- Kit includes one post and two mounting brackets. An additional center bracket is included for the 54" and 62" length posts. Hardware for mounting to wall not included

Step 2: Order Brackets

- Order one Single Shelf Bracket for each end of shelf
- Order one Double Shelf Bracket where shelves share a common post

Step 3: Order Shelves

- See page 15 & 17 for shelving options.



AMCO II® Wall Shelving Kit

- Kits include 1 or 2 wire shelves, one pair of brackets
- Holds 250 lbs. of evenly distributed static load per shelving unit
- Distance between the two shelves is 16-1/2"

Plating Plus™ Model No.	W x L x H (In.) (mm.)		Weight (Lbs.) (Kg)	
One-Shelf Kit				
W1236CP-1	12 x 36 x 11	305 x 915 x 280	12	5.5
Two-Shelf Kit				
W1236CP-2	12 x 36 x 29	305 x 915 x 737	24	11

Available in:

- 12", 18" and 21" widths, 36" and 48" lengths
- One-shelf kits available in 11", 18-1/2" and 21-1/2" heights
- Two-shelf kits available in 29", 36-1/2" and 39-1/2" heights



AMCO® Wall Shelving Kit With Wall Standards

- Kits include 1 or 2 wire shelves and one pair of wall standards and fasteners
- Holds 250 lbs of evenly distributed static load per shelving unit
- The distance between the two shelves is 9-1/2"

Plating Plus™ Model No.	W x L x H (In.) (mm.)		Weight (Lbs.) (Kg)	
One-Shelf Kit				
W1236CPSH-1	12 x 36 x 11.5	305 x 915 x 292	9	4
Two-Shelf Kit				
W1236CPSH-2	12 x 36 x 22	305 x 915 x 565	18	8

Available in:

- 12" and 18" widths, 36" and 48" lengths



AMCO II® Cantilever Wall Shelving

- Kits include 2 shelves, 2 posts, and fasteners
- Holds 60 lbs. of evenly distributed static load per shelving unit

Plating Plus™ Model No.	W x L x H (In.) (mm.)		Weight (Lbs.) (Kg)	
Two-Shelf Kit				
AC123618CP	12 x 36 x 18	305 x 915 x 565	20	9
AC124818CP	12 x 48 x 18	305 x 1220 x 565	26	12
AC183618CP	18 x 36 x 18	457 x 915 x 565	24	11
AC184818CP	18 x 48 x 18	457 x 1220 x 565	32	14.5



Kelmax Aluminum Boat Racks

- Wall, ceiling, and table-mount models available
- Table-mount will fit stainless steel or aluminum tables
- 15" deep, available in:
24" or 36" widths
48", 60", 72" or 96" lengths



Scan here to see our full selection of aluminum boat racks.

Kelmax Channel Wall Shelves

- Aluminum channel construction
- Load capacity is dependent on type of wall and mounting hardware

Model No.	No. of (Channels)	L x D (in.)	L x D (mm)	Weight (Lbs.)	Weight (Kg)
4H1404	1	36 x 12	914 x 305	7	3
4H1415	2	36 x 18	916 x 457	13	6



Universal® Stainless Wall Shelves With Sides Turned Down

- 16-ga. 300 Series stainless steel with rear turned up 2"
- Front and sides are formed down 1-1/2" at 90 degrees and back 1/2" at 45 degrees
- Includes 16-ga. stainless steel wall shelf brackets

Model No.	W x L (in.)	W x L (mm)
WSD-3612	12 x 36	305 x 914
WSD-4812	12 x 48	305 x 1219
WSD-6012	12 x 60	305 x 1524
WSD-3614	14 x 36	356 x 914
WSD-4814	14 x 48	356 x 1219
WSD-6014	14 x 60	356 x 1524

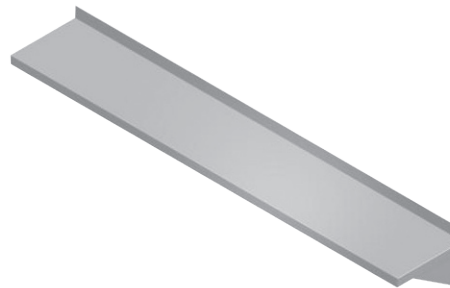

SPG's foodservice products are all manufactured to meet NSF standards. For specific items, visit www.nsf.org

Available in:

- 10", 12", 14" and 16" widths
- 2', 3', 4', 5', 6', 7', 8', 9' and 10' lengths
- 12" wide shelving weighs 4 lbs. (1.8 Kg.) / linear foot
- 14" wide shelving weighs 5 lbs. (2.3 Kg.) / linear foot

Universal® Stainless Microwave Shelves

- 16-ga. 300 Series stainless steel with rear turned up 1"
- Front formed down 1-1/2" at 90 degrees and back 1/2" at 45 degrees

Model No.	L x D (in.)	L x D (mm)	Weight (Lbs.)	Weight (Kg)
MWS-1824	18 x 24	457 x 610	15	7
MWS-24	24 x 24	610 x 610	20	9

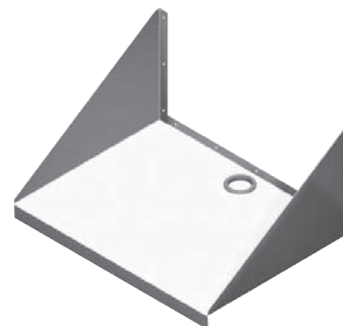

Universal® Stainless Wall Shelves With Pot Racks

- Manufactured from fully welded 3/16" x 2" 300 Series stainless steel flat-bar
- Includes single and double sided pot hooks

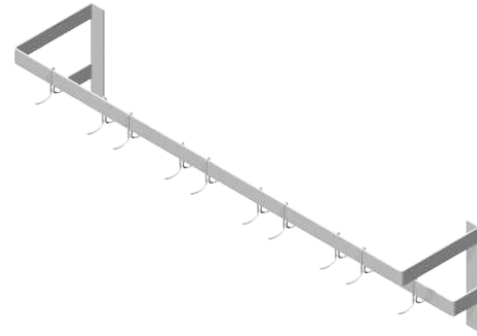

Model No.	L x D (in.) (mm)	Weight (Lbs.) (Kg)	Cu. Ft.
PR-WD-36-S	36 915	17 8	4
PR-WD-48-S	48 1219	26 12	5
PR-WD-60-S	60 1524	30 14	6

Also available in
7', 8', 9' and 10' lengths

Universal® Stainless Wall Mount Double Rail Pot Racks

- 16-ga. 300 Series stainless steel construction with rear turned up 2"
- Front turns down 1-1/2" at 90 degrees and back 1/2" at 45 degrees
- Pot rack is 3/16" x 2" stainless flat-bar fully welded
- Includes double-sided pot hooks

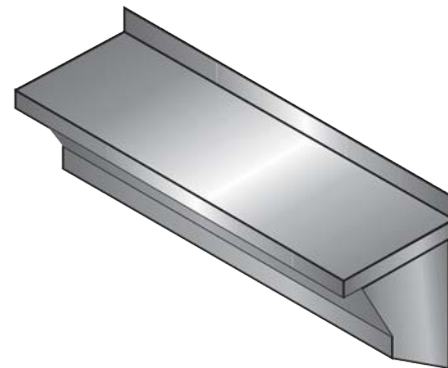

Model No.	L x D (in.) (mm)	Weight (Lbs.) (Kg)	Cu. Ft.
WSP-1248	12 x 48 305 x 1219	32 15	6
WSP-1260	12 x 60 305 x 1524	40 18	8
WSP-1272	12 x 72 305 x 1829	48 22	9

Also available in
7', 8', 9' and 10' lengths

Universal® Stainless Wall Mount Rack Shelf For Dish Area

Model No.	L x D (in.) (mm)	Weight (Lbs.) (Kg)	Cu. Ft.
WMRS-21	21 x 21 533 x 533	20 9	6
WMRS-42	42 x 21 1067 x 533	44 20	10
WMRS-63	63 x 21 1600 x 533	60 27	15



SPG: We Build Better Equipment So You Can Achieve Better Results.

While SPG manufactures shelving, sinks, carts, cabinets, racks, workstations and more, what we really offer you is productivity, efficiency, durability, versatility and performance. You'll find all of this in every product we sell and every service we provide. Beyond our innovative storage systems is a network of service and support that can help you maximize the performance of every square inch of space and every single employee in your facilities.

SPECIALTY SHELVING

Stock more products, more securely.

Whether you're in need of high security shelving to protect against theft, high-density shelving to maximize storage capacity or any other specialized product, you can look to SPG for proven solutions to meet any challenge you may face.



AMCO® Security Shelving

- Lockable wire enclosure limits opportunities to steal, reducing losses due to theft
- Provides a secure area with adjustable shelving for storage of costly items that tend to disappear
- 2"x 2" wire-spacing prevents small goods from being removed
- Door secures at both top and bottom, and handle has hasp design so it can be padlocked (padlock not included)
- Shelves and posts may be ordered in any available finish — enclosure available in Plating Plus™ finish only
- Available in stationary and mobile models — choose from a variety of standard caster offerings



4-Shelf Units

Model No. Stationary	Model No. Mobile	W x L x H (in.)	W x L x H (mm)	Weight (Lbs.)	Weight (Kg)
SU1300CP	SU1172CPMO	18 x 48 x 72	455 x 1220 x 1830	205	92
SU1316CP	SU1188CPMO	24 x 48 x 72	610 x 1220 x 1830	213	97
SU1302CP	SU1174CPMO	18 x 60 x 72	455 x 1525 x 1830	213	97
SU1318CP	SU1190CPMO	24 x 60 x 72	610 x 1525 x 1830	237	107.5

Also available: In 30-inch lengths

ISS™ Mobile Security Trucks

- Standard Security Trucks include: 4 posts; top and bottom shelves; 2 side panels; 2 back panels; 2 lockable front doors; 4 5" resilient stem swivel casters, 4 bumpers — order intermediate shelves separately
- Heavy Duty Security Trucks include a dolly frame with wraparound bumpers and 5" resilient plate casters



ISS™ Stationary Security Units

- Includes 4 posts, top and bottom shelves, 2 side panels, 2 back panels and 2 lockable front doors
- Order intermediate shelves separately

Plating Plus™ Model No.	Gold Bond® Model No.	W x L x H (in.)	W x L x H (mm.)	Weight (In.)	Weight (mm.)
SR536C	SR536Y	24 x 36 x 68	610 x 914 x 1742	131	60
SR548C	SR548Y	24 x 48 x 68	610 x 1219 x 1742	150	68
SR560C	SR560Y	24 x 60 x 68	610 x 1524 x 1742	177	79

Plating Plus™ Model No.	Gold Bond® Model No.	W x L x H (in)	W x L x H (mm)	Weight (Lbs.)	Weight (Kg.)
Standard					
SS536C	SS536Y	24 x 36 x 68	610 x 914 x 1742	140	63
SS548C	SS548Y	24 x 48 x 68	610 x 1219 x 1742	165	75
SS560C	SS560Y	24 x 60 x 68	610 x 1524 x 1742	188	86
Heavy Duty					
SH536C	SH536Y	24 x 36 x 68	610 x 914 x 1742	171	77
SH548C	SH548Y	24 x 48 x 68	610 x 1219 x 1742	198	90
SH560C	SH560Y	24 x 60 x 68	610 x 1524 x 1742	225	102

ISS™ Intermediate Shelves For Security Units

Plating Plus™ Model No.	Gold Bond® Model No.	W x L (in.)	W x L (mm.)	Weight (Lbs.)	Weight (Kg.)	Fits Units
2436C	2436Y	24 x 36	610 x 914	12.5	5	SS536C, SH536C, SR536C
2448C	2448Y	24 x 48	610 x 1219	16	7.3	SS548C, SH548C, SR548C
2460C	2460Y	24 x 60	610 x 1524	20	9	SS560C, SH560C, SR560C

Amtrax® II High Density Shelving

- High-density shelving that provides a solution to substantially increase storage capacity and utilize available space
- Uses overhead tracks to attach mobile storage units — the track is anchored onto floor-mounted stationary units at each end
- Mobile storage units can be rolled sideways to create a “live aisle” providing access to storage
- Allow 30” for “live aisle”

Add suffix CP for Plating Plus™ finish; add suffix PG for Polygard® (Blue) finish
Overhead Track (Available in CP finish only) maximum length 15 feet: Model No. AXTRACK

Model No.	Weight (Lbs.) (Kg)	
Stationary Unit Kit		
AX1	24	11
Mobile Unit Kit		
AX2	53	24

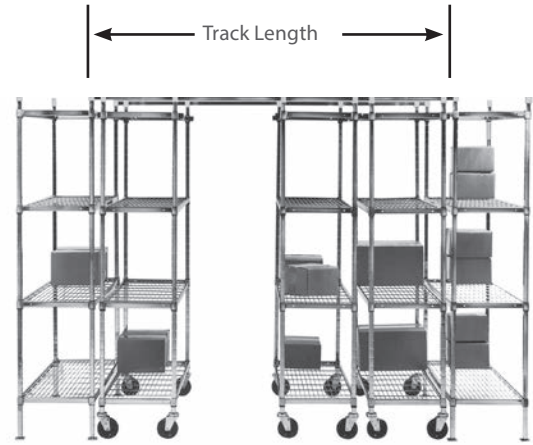

AMCO II® Ultra Density® Shelving

- Create Ultra Density® mobile storage with any size AMCO® posts and shelves and AMCO II® Ultra Density® casters
- Casters convert from rigid to swivel with foot lever
- When the casters are rigid the AMCO® square post shelving units stay in perfect alignment
- Mobile storage units can be positioned right next to each other and pulled out when needed by switching the caster to swivel
- No overhead track or “live aisle” required
- Increase efficiency and capacity while reducing labor costs
- Shelving ordered separately (AMCO II®, Plastic Plus®, Plasteel® options)

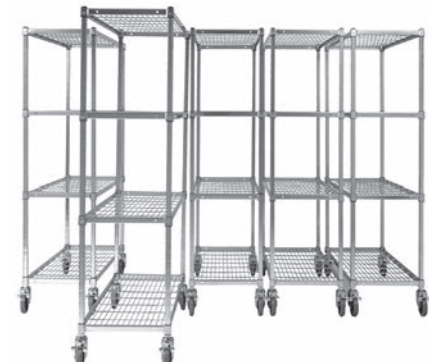

Model No.	Diameter (In.)	Face (In.)	Wheel Type	Tire Type	Capacity (Lbs.)	Weight (Lbs.)
AC8RS	5	1	Plastic	Urethane	250	3

ISS™ EZ Track™ High Density Storage System

- High efficiency storage offers a sliding mobile storage solution to gain additional storage space
- Uses overhead tracks to attach mobile storage units — the track is anchored onto floor mounted stationary units at each end
- Mobile storage units can be rolled sideways
- Utilizes “live aisle” space of 30” to 36” for moving units around and gaining access to storage area



Model No.	Description	Weight (Lbs.)
EZE	Fixed Unit	—
EZM18	Mobile Unit	18
EZM21	Mobile Unit	21
EZM24	Mobile Unit	24
EZT	Track Tube	—
EZJ	Joining Kit	—
CM6EZ	Caster	—

How To Order

- Order shelves and posts separately
- Order one EZE for each stationary unit
- Order one EZM for each mobile unit (Designate width of shelving by ordering EZM18, EZM21 or EZM24)
- Order four CM6EZ casters for each mobile unit
- Order EZT track equal to the total length of the system in even feet (EZT includes a pair of track)
- Order one EZJ joining kit for track lengths over 20 feet (Includes joining mechanism for both sections of track)

FREESTYLE® WORKSTATIONS

Prepare for a higher level of productivity.

Strength and durability...speed and efficiency...storage and workspace — it's all built in to an ergonomically designed workstation that will help your staff become more efficient and your operation more profitable.



- The ergonomic design maximizes usable kitchen space and provides added storage for packaging, smallwares, menus, ingredients, utensils and more
- An impressive total load-bearing capacity of 2,800 lbs.
 - each upper shelf has a 600-lb. capacity
 - bottom shelf capacity is 1,000 lbs.
- Plug and place steamers, microwaves, food warmers and other standard equipment
- Fast, easy cleaning of food prep surfaces and overall structure
- 30" deep stainless steel work surface provides plenty of area for prep work
- Open-base design delivers adequate space for a fridge under the work surface of the 48", 54" and 60" models
- Shelf and work surface heights adjust in 2" increments
- Add components or shelves without tools
- No front uprights for an uninterrupted work surface

Before you choose a workstation, consider why so many major national foodservice operations have turned to Freestyle® to improve storage, efficiency and productivity.

Freestyle® combines the versatility and flexibility of a freestanding unit while providing rock-solid strength and stability to support steamers, microwaves and other vital equipment

From the ability to add or reconfigure shelves quickly and without tools to the wide selection of accessories available — everything about Freestyle® is customizable.

Unlike most competitive units, Freestyle® doesn't require a bottom shelf for stability — freeing up floor space underneath for a refrigerator at a prep station or a safe at the Drive-Thru.

Storage is enhanced by virtue of a 2,800-lb. unit capacity...shelves that can be positioned in 2" increments...and shelf surface areas that are uninterrupted by front uprights.



Turn the page to find SPG Drive Thru products.



SPG's foodservice products are all manufactured to meet NSF standards. For specific items, visit www.nsf.org

Customizable with a complete line of accessories:

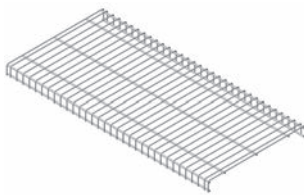

Wire Shelf Cover



Solid Shelf Cover



Grid Basket

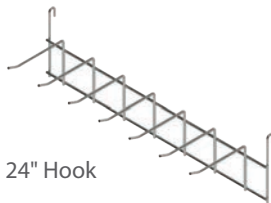

24" Hook



Spoodle Holder

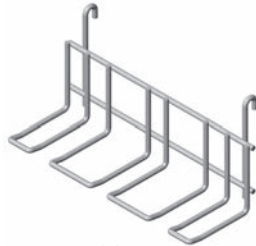

Scoop Holder



Hanger Rails

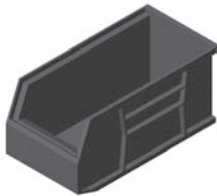

Bins



Pot Hook Grey

Model No.	Prep Surface Widths	Overhead Shelf Widths	Lengths	Inside Clearance
WST1491E	30" (762 mm)	18" (457 mm)	60" (1524 mm)	56" (1429 mm)
WST1539E	30" (762 mm)	18" (457 mm)	54" (1372 mm)	50 (1276 mm)
WST1492E	30" (762 mm)	18" (457 mm)	48" (1219 mm)	44 (11245 mm)
WST1493E	30" (762 mm)	18" (457 mm)	36" (914 mm)	32 (819 mm)

Need Even More Capacity?

The innovative Freestyle® Brace can quickly and easily increase the weight capacity of a Freestyle® by 200 lbs. or 400 lbs. per shelf. (See page 25 for details.)



Scan here to see our Freestyle® spec sheet

EXTRAORDINARY EFFICIENCY

From preparing the order to staging and serving, SPG has a complete line of products to make your Drive-Thru service faster, more efficient and more profitable.



ISS™ Drive-Thru Workstation

- 30" x 60" baseline drive thru workstation provides the ultimate in organization, accessibility and workspace
- Minimizes time, motion and effort required to stage orders
- Comes with overhead storage area, condiment bins, lower storage shelving area — and open area to accommodate undercounter equipment needs
- Can also be converted to use our condiment tower and order stager system
- Choose from Plating Plus™, Grey Bond® or Gold Bond® finishes
- Also available in:
 - 18", 24", and 36" depths
 - 30", 36", 42", 48", 54" and 60" lengths

Model No. WST1363Y

For an assembled unit, add "A" as suffix to the model no.



SPG's foodservice products are all manufactured to meet NSF standards. For specific items, visit www.nsf.org

Looking for more options?
See our Freestyle® workstation
on page 38.



ISS™ Open Base Workstation

- 30" x 30" baseline multi-purpose workstation is ideal as a prep station, drive-thru counter, sandwich-making stand, or equipment stand
- Available in all standard depths and lengths
- Upper and lower storage shelving
- Choose from a wide array of posts, shelves, shelf covers and accessories
- Durable design with shelves rated to support 1,250 lbs. of uniformly distributed weight
- Features Gold Bond® finish and a 10-year warranty against corrosion
- Available in a variety of essential sizes

Model No. WTO3030Y

For an assembled unit, add "A" as suffix to the model no.



ISS™ Present Cart



- This highly versatile system is ideal for drive-thru and counter applications
- Solid stainless steel top, hanger rail and pulp tray holder are attractive, durable and easy-to-clean
- Three wire shelves deliver added storage and utility
- Includes four posts with smooth-rolling 5" (127mm) resilient casters with brakes for maximum maneuverability, control and easy item transport

Model No.	W x L x H (In.)	W x L x H (mm.)
WST1350CA	12 x 36 x 35	305 x 910 x 889

ISS™ Under-Counter Condiment Cart



- Three open wire shelves, each with a built-in ledge to prevent condiment bins from falling
- Digital posts with casters
- Three bin blocker bars (one per shelf) prevent condiment bins from sliding to the back of each shelf

Model No.	Bins	L x W x H (In.)	L x W x H (mm)
WST1082C	12	18 x 24 x 24.5	455 x 610 x 623

ISS™ Order Stager



- Countertop organizer keeps orders separated and in proper sequence
- Right-to-left order flow
- Includes 3 divider bars and Divider Bar Holder (not shown in photo)

Model No.	W x L x H (In.)	W x L x H (mm.)	Weight (Lbs) (Kg.)	
ORDSTAGL	21 x 30 x 6	540 x 762 x 152	6	3

ISS™ Condiment Towers



- A proven system to speed customers through at the counter and the drive thru window
- Gravity-fed bins keep condiments organized and deliver first-in, first-out inventory control
- Kit includes: two 29" gray posts, two 15" gray posts, 3-sided frame, 18" hanger bar, five 3-way bins; straw holder
- Two order flow options (left-to-right is "R" model; right-to-left is "L" model)
- Strong, wear resistant ABS plastic
- Also available in 18" lengths
- Shown with ISS™ Order Stager (not included)

Model No.	W x L x H (In.)	W x L x H (mm.)	Weight (Lbs) (Kg.)	
CONDTOW24L	24.5 x 24.5 x 30.5	622 x 622 x 750	3	14
CONDTOW24R	24.5 x 24.5 x 30.5	622 x 622 x 750	3	14

SUPERIOR SELECTION

SPG offers all kinds of carts in a wide range of sizes, styles and materials — including stainless steel, aluminum, wire, steel and plastic — all designed to deliver better performance, efficiency and economy.



Kelmax Rocket Cart

Sure to be one of the most used pieces of equipment in your organization, this incredible workhorse can be reconfigured quickly and easily to handle a wide range of jobs.

- Ergonomic and space-saving design improves stocking efficiencies and maximizes labor savings
- Galvanized steel construction provides strength, durability and an extended service life
- Vertical supports and shelf collapse and fold in to allow for nesting of several units to conserve valuable backroom space
- Split shelf design makes it easier to stack product
- Dual shelf designed to handle a variety of package sizes or provide a flat, stable work surface
- Compact design reduces aisle congestion and promotes safer, easier shopping experience for customers
- Includes a convenient pull handle, paper towel holder, and a hook to hang a trash bag

Model No.	Overall Dimensions	Weight
4G0786	26" W x 41" L x 69" H	114 Lbs.



Kelmax Produce Stocking Cart

- Versatile 2-tier high-capacity design
- Heavy duty galvanized solid top shelf (22" x 44")
- Galvanized square tube bottom shelf
- 5" polyurethane plate casters; 2 swivel and 2 rigid



Scan here to see our Wet Produce Utility Cart on page 28 of the Kelmax catalog.



Model No.	Capacity (Lbs.)	L x W x H (In.)	L x W x H (mm)	Weight (Lbs.) (Kg)	
4G0172	800	51 x 22 x 36	1295 x 559 x 914	64	29

Also available with bumpers (Model No. 4G1073)

Universal® Stainless Steel Meal Delivery Carts

- Heavy-duty 18-ga. 300 Series stainless steel resists corrosion and is ideal for harsh, high-moisture environments
- Choose from single, double or pass-through models
- Includes removable tray racks for maximum flexibility and easier maintenance
- Double pan hinged doors with paddle latches open a full 270 degrees for easy access
- Four 5" casters (2 with brakes), vinyl corner bumpers
- Non-insulated; NSF compliant
- 2-year parts and labor warranty



Model No.	L x W x H		Tray Capacity	Tray Spacing	Weight	
	(In.)	(mm)			(In.)	(Lbs.)
Single Door						
DS-MC-1-5-16	34 x 26 x 50	864 x 660 x 1270	16	5	244	111
DS-MC-1-5-18	34 x 26 x 55	864 x 660 x 1397	18	5	261	118
DS-MC-1-5-20	34 x 26 x 60	864 x 660 x 1524	20	5	278	126
DS-MC-1-5-24	34 x 26 x 70	864 x 660 x 1778	24	5	312	142
Double Door Pass Thru						
DS-MC-2-5-16	35 x 26 x 50	889 x 660 x 1270	16	5	264	119
DS-MC-2-5-20	35 x 26 x 60	889 x 660 x 1524	20	5	302	137
DS-MC-2-5-24	35 x 26 x 70	889 x 660 x 1778	24	5	340	154
Double Wide						
DS-MC-3-5-28	34 x 49 x 45	864 x 1245 x 1143	28	5	343	156
DS-MC-3-5-32	34 x 49 x 50	864 x 1245 x 1270	32	5	372	169

Stainless Steel and Aluminum delivery carts designed to hold 14" x 18", 15" x 20", 18" x 26" trays

Kelmax Aluminum Meal Delivery Carts

- Aluminum construction
- All-welded units with double pan top
- Door opens 270 degrees on stainless steel hinges
- Stainless steel gravity latch is drilled for padlock
- Four 5" poly swivel casters
- Holds 14" x 18" or 15" x 20" Trays (except 4H2200)
- Non-insulated; NSF certified

Model No.	L x W x H		Tray Capacity	Tray Spacing	Weight	
	(In.)	(mm)			(In.)	(Lbs.)
Single Door						
4H6791	32 x 24 x 39	813 x 610 x 991	10	6	85	39
4H6792	32 x 24 x 45	813 x 610 x 1143	12	6	94	43
4H6793	32 x 24 x 51	813 x 610 x 1296	14	6	103	47
4H6794	32 x 24 x 57	813 x 610 x 1448	16	6	112	51
4H6795	32 x 24 x 63	813 x 610 x 1600	18	6	121	55
4H6796	32 x 24 x 69	813 x 610 x 1753	20	6	130	59
4H6797	32 x 24 x 45	813 x 610 x 1143	24	3	104	47
4H2200*	21.5 x 28 x 69	546 x 711 x 1753	40	1.5	105	48

*Holds 18" x 26" or 18" x 13" Trays



SPG's foodservice products are all manufactured to meet NSF standards. For specific items, visit www.nsf.org

EXCEPTIONAL ECONOMY

Throughout our extensive product line-up, SPG offers the lowest cost of ownership to help you drive out costs while driving up productivity.



ISS Contender™ Utility Carts

- Ideal for receiving, busing and general material handling
- Wire construction; 2-shelf or 3-shelf models
- Easy maneuverability with 5" diameter, swivel, resilient, non-marking casters
- Assembly requires no tools or extra hardware
- Plating Plus™ — zinc plating, chromate steel and clear lacquer form a finish that's hard, durable and attractive
- Load rating is 800 lbs.



Model No.	W x L x H (In.)	Weight
2-Shelf Utility Carts		
MUC18302C	18 x 30 x 39	37
MUC18362C	18 x 36 x 39	40
MUC24362C	24 x 36 x 39	47
3-Shelf Utility Carts		
MUC18303C	18 x 30 x 39	43
MUC18363C	18 x 36 x 39	47
MUC24363C	24 x 36 x 39	60

ISS Contender™ carts are also available with Contender Grey™ Epoxy finish for humid and moist environments. Custom handles are also available. Call your SPG representative for details.

Kelmax Heavy Duty Stainless Steel Utility Cart

- A reinforced tube adds strength under front lip of shelves
- 5" x 2" polyurethane plate casters
- 1,100 lb-rolling capacity
- Stainless steel caster hardware
- Made in 304 Series stainless steel for rust resistance



Model No.	No of Shelves	Shelf Spacing(In.)	Shelf Size	W x L x H		Weight	
				(In.)	(mm.)	(Lbs)	(Kg.)
4J0473	2	23	18 x 32	37.5 x 19.5 x 37	953 x 496 x 940	74	34
4J0407	3	11	18 x 32	37.5 x 19.5 x 37	953 x 496 x 940	90	41

Kelmax stainless steel Utility Carts are available in:
 37-1/2", 38-1/2" and 54-1/2" lengths
 19-1/4" and 22-1/2" widths

See our line of Kelmax cart accessories on page 76.



ISS™ Universal Staging Cart

- Provides maximum cooler storage in minimum space
- Improves thawing and storage capabilities, facilitates product rotation and includes 12 aluminum trays
- Ideal for any product that needs tempering in a walk-in cooler
- End-loading rack offers generous capacity and can hold up to 28 trays
- Assembles without tools—thanks to our Sure Lock™ coupler, numbered posts and easy instructions

Model No.	W x L x H	
	(In.)	(mm.)
WST1384Y	21 x 30 x 68.5	533 x 762 x 1740

Kelmax Aluminum Meat Lug Carts

- All welded construction
- 5" polyurethane swivel stem casters



Model No.	Lug Capacity	L x W x H		Weight	
		(In.)	(mm.)	(Lbs)	(Kg.)
4H0682	1	25 x 16 x 19	635 x 406 x 483	10	4.5
4H0690	2	25 x 16 x 33	635 x 406 x 838	18	8
4H0694	6	27 x 19 x 69	686 x 483 x 1753	30	13.5

Kelmax Meat Lug Carts are also available in 3 and 4-lug capacities
Order lugs separately - see page 76



SPG's foodservice products are all manufactured to meet NSF standards. For specific items, visit www.nsf.org

Kelmax Mixing Bowl Dolly

- Designed for the toughest conditions
- 16-ga. 304 Series stainless steel construction tubing with .25" thick ring
- 800 lb. capacity
- Mobile unit on 5" polyurethane casters

Model No.	Ring Size (In.)	L x W x H		Weight	
		(In.)	(mm.)	(Lbs)	(Kg.)
4J0274	19	28 x 21 x 30	711 x 533 x 761	45	20

Available with 19" and 30" rings, in 26" and 30" heights



MAXIMUM MOBILITY

Whether you need to maneuver in tight, busy kitchen spaces or transport meals, supplies and more — SPG has a complete selection of products to help move your operation forward.



Kelmax Aluminum Sheet Pan Dolly

- Store and transport foodservice trays with greater efficiency and convenience
- One or two tier units
- Holds 18" x 26" sheet trays
- 5" polyurethane swivel plate casters
- Heavy-duty units have 1-1/4" square tubing
- All welded aluminum construction

Model No.	Capacity (Lbs)	L x W x H		Weight	
		(In.)	(mm.)	(Lbs)	(Kg.)
4H1331	900	27 x 22 x 32	686 x 559 x 813	22	10



Tray Modules Mobile Unit

- Space saving cart for storing trays
- Each cart consists of 4 shelves, 4 posts, four 5" CM5M swivel casters, 4 donut bumpers and tray modules to fill each shelf tray
- Tray module is TM241PG, spacing is 1-9/16"
- Shelving is 24" wide, 77" high

Polygard® Model No.	Tray Cap.	Length (In.)	Length (mm.)	Weight (Lbs.)	Weight (Kg.)
TM2448PG	96	48	1220	160	72.6
TM2460PG	112	60	1525	190	86.2
TM2472PG	144	72	1830	206	93.4



AMCO® Dishwasher Rack Dolly

- Rugged polypropylene construction
- Durable rubber 4" dia. swivel casters
- Reduces ware handling, breakage — increases staff efficiency and productivity
- Easily moves 150 to 180 glasses
- 2" deep waste well stops water from dripping onto the floor
- Sized to fit all brands of dishwasher racks
- Color: Brown

Model No.	(In.)	W x L x H		Weight	
		(mm.)	(mm.)	(Lbs)	(Kg.)
232	21 x 21 x 7	540 x 540 x 178		12	5
233	21 x 21 x 36	540 x 540 x 914		17	8



Model No. 232

Model No. 233

Download our complete foodservice equipment catalog at spgusa.com



Universal® Stainless Janitor Carts

- Choose from heavy-duty epoxy-coated finish or 18-ga. Series 301 stainless steel construction
- Easy to clean and built to withstand constant heavy use
- Ideal for linen, recycling, trash collection and more
- Ergonomic design offers more flexibility, safety
- Shelves can be easily adjusted without tools
- Features include a folding handle, locking two-shelf cabinet, three mop/broom holders and a platform to hold mop bucket(s)
- Vinyl corner bumpers help prevent scratches to furniture and walls
- 5" sturdy casters — including two with locks
- Double Bucket version features fold-up platform for easier storage



SPG's foodservice products are all manufactured to meet NSF standards. For specific items, visit www.nsf.org

Epoxy-Coated Model No.	W x L x H (In.)	Stainless Steel Model No.	W x L x H (In.)	Weight (Lbs.)	Weight (kg.)
Single Bucket Platform					
CRT-JANITOR-P10	57 x 18.5 x 42	CRT-JANITOR-S10	57 x 18 x 42	123	56
Double Bucket Platform					
CRT-JANITOR-P22	69 x 18.5 x 42	CRT-JANITOR-S22	69 x 18 x 42	130	59
Accessories Include:					
18-ga. 300 Series stainless steel collection bag cover: Model No. CVR-JCRT-S					
Heavy-duty epoxy coated collection bag cover: Model No. CVR-JCRT-P					
Nylon collection bag — 18" x 12" x 20": Model No. JCB1218N					
Vinyl collection bag — ideal for wet messes: Model No. JSB1218V					



Kelmax U-Boat

- Heavy-duty dual steel channel base deck
- 6-wheel design offers maximum maneuverability
- 2 - 8" rigid center polyurethane wheels
- 4 — 4" swivel polyurethane end casters
- One U-Boat does the work of five (5) hand trucks
- 24" deck is available when a larger capacity is needed



Scan here to see the vast selection of U-Boats in the SPG Material Handling Catalog.

Model No.	Capacity (Lbs)	W x D (In.)	W x D (mm.)	Weight (Lbs)	Weight (Kg.)
4G0251 16" Deck U-Boat	2,500	60 x 16	1524 x 407	87	39
4G0372 16" Deck U-Boat	2,500	48 x 16	1219 x 407	90	40
4G0263 18" Deck U-Boat	2,000	60 x 18	1524 x 457	105	47
4G0276 24" Deck U-Boat	2,000	60 x 24	1524 x 610	120	54
4G0722 Shelf 16 x 48	—	16 x 48	407 x 1219	26	12
4G0729 Shelf 16 x 60	—	16 x 60	407 x 1524	29	13

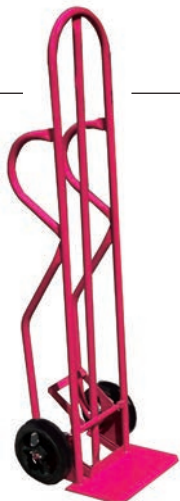

Kelmax Hand Trucks

- Beveled plate and heavy-duty steel construction
- Easy-to-control loop handle
- SPG's unique Kick-Off feature makes it easier to unload products

Model No.	Handle Type	Wheel Type	Capacity (Lbs)	Weight (Lbs)	Weight (Kg.)
4K0163	Loop Handle	Semi Pneumatic	600	35	16

INSPIRED INNOVATION

The patent-pending design of our Collapsible Nesting Pan Rack is incredibly space-efficient...and representative of the kind of thinking that goes into all SPG racks.



Kelmax Collapsible Nesting Pan Rack

- Patented design collapses into “V” shape for nesting and easier transporting of multiple racks
- Fully collapses to reduce storage footprint by 50%
- Unique, locking hinge mechanism creates exceptional strength and rigidity
- Rugged, welded aluminum design, heavy-duty tray slides, and reinforced gussets for maximum durability
- 5” polyurethane casters for optimum maneuverability
- Holds eighteen 18”x 26” pans with 3” spacing between tray slides
- Optional 304 Series stainless steel construction is available for specialized applications

Model No.	W x L x H (In.)	W x L x H (mm.)	Tray Capacity	Weight (Lbs.)	Weight (Kg.)
4H6848	21 x 27 x 69	533 x 686 x 1753	18	44	20

Optional sizes and tray capacities available



Featured in the NAFEM showcase of innovative products



Scan here to see our video.

Kelmax Aluminum Standard Duty Pan Racks

- Round tops and reinforced gussets for greater strength
- Runners welded to uprights
- Holds both 18” x 26” sheet pans and 14” x 18” trays
- Units have standard 5” polyurethane casters
- Lifetime guarantee against rust



Scan here for a complete list of available sizes, features and options.

Model No.	Tray Capacity	Spacing (In.)	D x L x H (In.)	D x L x H (mm.)	Weight (Lbs.)	Weight (Kg.)
End Load						
4H0855	12	5	26 x 21 x 69	660 x 533 x 1778	38	17
4H0963	20	3	26 x 21 x 69	660 x 533 x 1778	45	20
4H1023	25	2.5	26 x 21 x 69	660 x 533 x 1778	47	21
Side Load						
4H0880	12	5	29 x 18 x 69	457 x 737 x 1778	35	16
4H0953	18	3	29 x 18 x 64	457 x 737 x 1626	38	17
4H1039	30	2	29 x 18 x 69	457 x 737 x 1778	43	20

Aluminum Standard Duty Pan Racks are available with tray capacity from 10 to 30 Half sizes and custom sizes are also available to hold other types of trays Rack covers, caster options, brakes, bumpers are also available





ISS™ Rolling Pastry Rack

- Ideal for the storage of pastry backstock, packaged food, food trays
- Nine (9) wire shelves for storing and rotating inventory
- Marine waterfall shelf edge for easy loading and unloading
- Highly mobile with 5" swivel casters, 2 with brakes
- Patented Sure Lock™ coupler and numbered posts ensure easy, tool-free assembly
- Plating Plus™ — carbon steel plated with bright zinc and lacquer-coated for a tough, durable finish

Model No.	Width (In.)	Length (In.)	Height (In.)	Weight (Lbs.)
STBK524MC	24	24	76.5	144

Kelmax Aluminum Heavy Duty Racks

- .100" thick runner
- All-welded construction
- 5" poly U swivel plate casters
- 1-1/4" heavy wall uprights
- Heavy-duty wheel channel



SPG's foodservice products are all manufactured to meet NSF standards. For specific items, visit www.nsf.org

Model No.	Tray Capacity	Spacing (In.)	D x L x H (In.)	D x L x H (mm.)	Weight (Lbs.)	Weight (Kg.)
4H0950	18	3	26 x 21 x 65	660 x 533 x 1651	66	30
4H0991	20	3	26 x 21 x 69	660 x 533 x 1753	70	32



Kelmax Aluminum Oven Rack

- Oven racks accommodate three common lifts: A-Lift, B-Lift, C-Lift
- Includes rack, lift and high temperature casters
- Standard runners are 1" x 1-1/2" wide, custom runners available
- Holds 18" x 26" sheet pans or 20" x 30" trays

Model No.	D x L x H (In.)	D x L x H (mm.)	Number of Runners	Spacing (In.)
4H5433	26 x 20 x 71	660 x 518 x 1813	15	4



SPG: Your Source For Oven Racks

SPG offers oven racks for all of the industry's most popular oven brands, including: Hobart, Revent, Baxter, Adamatic, Lucks and Bakers Aid.

- Aluminum or stainless steel construction
- End-load, side-load, and double-side load configurations
- A variety of spacing and capacity options
- A selection of high-temperature casters options

THE RIGHT RACKS

From enclosed cabinets and steam racks to can racks and dunnage, SPG offers a vast selection of storage systems designed for specific tasks — and to help your operation run more smoothly and profitably.



Kelmax Enclosed Cabinets

- Great for areas where cabinets will be in public view such as hospital hallways or dining halls
- Tray spacing on 1" or 1-1/2"
- All welded units with double pan tops
- Door opens 270 degrees on stainless steel hinges
- Stainless steel gravity latch is drilled for padlock
- Heavy-duty models have reinforced center supports and standard 5" x 2" casters

Download our complete
foodservice equipment catalog
at spgusa.com



Model No.	Tray Capacity	Spacing (In.)	D x L x H (In.) (mm.)		Weight (Lbs.)	Weight (Kg.)
End-Load — 1 1/2 in. Spacing						
4H2179	16	1.5	28 x 22 x 32	711 x 559 x 813	80	36
4H2187	24	1.5	28 x 22 x 44	711 x 559 x 1118	95	43
4H2193	32	1.5	28 x 22 x 56	711 x 559 x 1422	95	43
4H2200	40	1.5	28 x 22 x 68	711 x 559 x 1727	105	48
End-Load — Heavy-duty — 1 1/2 in. Spacing						
4H2223	40	1.5	28 x 22 x 68	711 x 559 x 1727	115	52
Side-Load — 1 1/2 in. Spacing						
4H2195	32	1.5	20 x 31 x 56	508 x 787 x 1422	92	42
End-Load — Heavy-duty — 1 in. Spacing						
4H2229	60	1	28 x 22 x 68	711 x 559 x 1728	115	52

Kelmax Keg Dunnage Racks

- Organize inventory and optimize keg storage space
- Keep kegs off the floor to reduce the chance for damage
- Heavy-duty 1-1/2" x 2" tubular frame
- "E" channel laterals run front to back to allow sliding of kegs
- All-welded aluminum construction
- Lifetime guarantee against rust

Model No.	Number of Kegs	W x L x H (In.)	W x L x H (mm.)	Weight (Lbs.)	Weight (Kg.)
4H2237	2	18 x 36 x 12	457 x 915 x 305	9	4

Kelmax Keg Dunnage Racks are available in 18" and 24" widths, and 36" and 48" lengths — call for details



Check out more keg rack options
on page 65.



Kelmax Poly Food Box Racks

- Ideal for transporting and holding poly food boxes from the service area to the kitchen
- Great for helping sort products in the cooler
- Strong 1" square tubular aluminum construction
- Durable 5" poly U swivel stem casters

Model No.	Tray Capacity	Spacing (In.)	D x L x H (In.) (mm.)		Weight (Lbs.) (Kg.)	
4H0728	5	6	26 x 21 x 38	660 x 533 x 965	26	12
4H0731	8	6	26 x 21 x 69	660 x 533 x 1753	31	14
4H0721	15	4	26 x 21 x 69	660 x 533 x 1753	36	16
4H0724	20	3	26 x 21 x 69	660 x 533 x 1753	42	19

Some soft side boxes will not work in these racks



SPG's foodservice products are all manufactured to meet NSF standards. For specific items, visit www.nsf.org



Kelmax Standard Tubular Dunnage Racks

- Square Tubular Dunnage Racks are an economical way to hold medium to heavy-duty boxes
- All units come with a lifetime guarantee against rust
- Extra-strong 1-1/2" square aluminum tubing
- Plastic cap feet
- 8" legs

Model No.	L x D (In.)	L x D (mm.)	Capacity	Weight (Lbs.) (Kg.)	
20-in. Wide Racks					
4H1752	20 x 36	508 x 914	2100	8	4
4H1810	20 x 48	508 x 1219	1800	10	5
4H1853	20 x 60	508 x 1524	1500	13	6
24-in. Wide Racks					
4H1759	24 x 36	610 x 914	2100	9	4
4H1818	24 x 48	610 x 1219	1800	12	5
4H1857	24 x 60	610 x 1524	1500	15	7

Also available with 12" legs. Welded cap is an available option



ISS™ Plastic Dunnage Racks

- Lightweight one-piece seamless polyethylene
- Rust and corrosion-proof
- Slotted to provide excellent air circulation
- Use in dry storage or in walk-in coolers/freezers
- Guaranteed for up to 10 years
- Holds up to 2,000 lbs. (907 kg.)
- Fits flush to adjacent units to maximize space utilization

Model No.	W x L x H (In.)	Number of Legs	Weight (Lbs)
DUN2436	24 x 36 x 12	4	14
DUN2448	24 x 48 x 12	6	18
DUN2448	24 x 60 x 12	6	25

HIGHER CAPACITY

With storage capacity up to 150 No. 10 cans...a patented system that grows with your operation ... automatic FIFO inventory rotation...easy loading and easy access — SPG has a unique capacity for creating efficient storage solutions.



AMCO® Take 10® Can Storage

This patented, gravity-fed can storage system delivers front load/front unload FIFO inventory control — Take 10® maximizes your storage space while providing unparalleled access to inventory.

- You can use Take 10® modules on your existing shelving or purchase a complete can storage system
- Modules can be stacked atop each other so that your storage system can expand as your needs grow, while conserving valuable space
- Fits onto all brands of shelving at least 18" deep and 42" long



SM-10



SM2-MB

Model No.	Description	Can Cap	W x L x H		Weight	
			(In.)	(mm.)	(Lbs.)	(Kg.)
SM-10	Can Storage Module	30	21 x 40 x 18.5	535 x 1015 x 464	35	16
2-SM10	Stationary Base, 2 Modules	60	21 x 40 x 36.5	535 x 1015 x 927	70	32
SM2-MB	Mobile Base, 2 Modules	60	21 x 42 x 51	535 x 1065 x 1295	127	58

The Best Names In The Business All Have One Thing In Common: The SPG Name.

Within the SPG product line-up, you'll find the most well-known and respected names in foodservice equipment. Each of our lines brings its own unique features, benefits and efficiencies to foodservice operations, and together they offer an outstanding combination of selection, quality and value.

- AMCO®
- ISS™
- KELMAX
- FREESTYLE®
- ISS CONTENDER™
- UNIVERSAL® STAINLESS
- GILLIS
- JARKE®

Kelmax Full Size Can Racks



- Organize your stock room with the 4H1580 unit
- Ships set up, ready to use
- FIFO Can Rack holds 156 cans — 13 cans per opening
- FIFO is First In - First Out; load and empty from front
- All welded aluminum construction will never rust
- Mobile kit available factory installed for safety
- 5" poly U plate casters, 2 swivel w/brakes and 2 rigid

Model No.	Capacity of No.10 Cans	D x L x H (In.) (mm.)		Weight (Lbs.) (Kg.)	
Full Size Unit — Holds 6 Cans Per Opening					
4H1580	162	35 x 25 x 71	889 x 635 x 1803	60	27
FIFO Can Rack					
4H3054	156	42 x 28 x 79	1067 x 711 x 2006	166	75

Full-size units are also available in a variety of dimensions with can capacities of up to 216, call for additional choices.

Kelmax Half Size Can Racks



- Unit doubles as work table so you maximize your space
- Available with aluminum top, 304 Series stainless steel top or 5/8" poly top
- 5" poly U expandable stem casters, 4 swivel, 2 with brakes
- Ships set up, ready to use

Model No.	Capacity of No.10 Cans	Type of Top	D x L x H (In.) (mm.)		Weight (Lbs.) (Kg.)	
4H1603	54	Aluminum	35 x 28 x 35	889 x 711 x 889	54	24
4H1604	54	Poly Top	35 x 28 x 35	889 x 711 x 889	65	29
4H1606	54	Stainless Steel	35 x 28 x 35	889 x 711 x 889	61	27

Half-size can racks are also available in 48" height/72 can capacity, call for additional choices.

Kelmax Insert Rack



- Insert Racks for freezers and coolers
- Fits most reach-ins with 21" door clearance
- Standard runner holds 18" x 26" Pans
- Universal runner holds both 12" x 20" steam table pans and 18" x 26" sheet pans

Model No.	Tray Capacity	Spacing (In.)	D x L x H (In.) (mm.)		Weight (Lbs.) (Kg.)	
4H0932	16	3	24 x 21 x 51	610 x 533 x 1295	26	12



SPG's foodservice products are all manufactured to meet NSF standards. For specific items, visit www.nsf.org

INSPIRED INGENUITY

We not only imagine products that create efficiencies, improve productivity, cut costs and reduce employee injuries — we build them, too.



Both the Universal® Stainless Adjustable Ergo Table and Deli Slicer are designed with a fold-away hydraulic crank — so the work surface can be raised or lowered quickly and easily. As a result, these innovative tables provide a customized fit for each employee — to improve staff comfort, increase productivity and optimize efficiency.

Featured in the NAFEM showcase of innovative products



Universal® Stainless Adjustable Ergo Table

- Quickly, easily adjust table surface heights from 30" - 42" or from 34" - 40"
- Uses 100% food-safe hydraulic fluid in a closed-loop system
- All models feature bullet feet, and can be ordered with casters by adding the suffix C to the part number.



Model Number	L x W (In.)	Working Surface
Stainless Steel Work Surface		
48SLCA12-30	48 x 30	301 Stainless Steel Tops/Pans
60SLCA12-30	60 x 30	301 Stainless Steel Tops/Pans
Poly-Top Work Surface		
48MCTA12-30	48 x 30	Poly Top & Tabs Added
60MCTA12-30	60 x 30	Poly Top & Tabs Added

Universal® Stainless Adjustable Deli-Slicer

- Work surface adjusts from 34" to 40"
- 36" x 30" table with marine edge 16-ga. 300 Series stainless steel
- Under shelf 18-ga. 300 Series stainless steel
- 2" square stainless steel leg tubes
- Four 4-inch locking casters
- Work surface adjusts from 34" to 40"



Model Number	L x W (In.)	Working Surface
SS-3630-A6-C	36 x 30	300 Series Stainless Steel



Scan here to see the Universal® Stainless adjustable tables in action



SPG's foodservice products are all manufactured to meet NSF standards. For specific items, visit www.nsf.org

Universal® Stainless Modular Counter System

SPG can customize an integrated counter system that's perfectly tailored to your space and your work processes. Seamlessly integrated top-of-the-line materials combined with ergonomic design create a system that maximizes utility, optimizes workflow, improves storage and promotes a clean, organized workspace.

The modular counter system will deliver the lowest cost of ownership and drive staff productivity in every area of your operation — including:

- Drive-Thru
- Dining
- Food Prep
- Bakery
- Front Counter Operations

Among the many features we can incorporate into your system are:

- Tables, open bases, cabinets, side panels
- Wire or solid shelving
- One-piece tops — flat, marine edges or even configured for natural stone
- Integrated drip-trough and spray grommet
- Easy access to electrical, plumbing, data services
- Sectioned base that allows custom configurations of equipment and shelving
- Integrated trash section
- Sink bowls
- Backsplash receptacles
- Cut-outs for drop-ins

— or just about any other option you require.

For the ultimate in efficiency, flexibility and productivity, contact your SPG representative for more details.

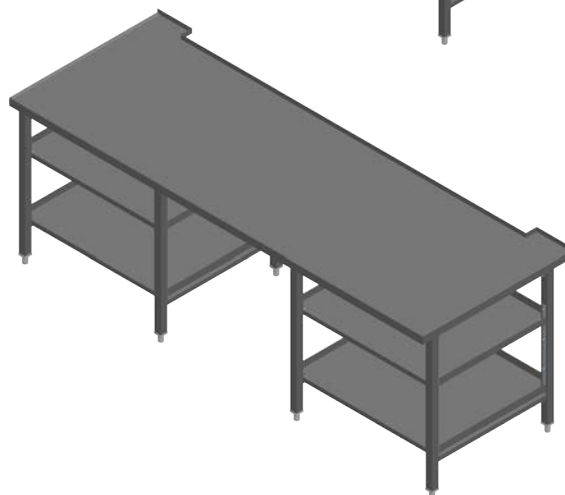
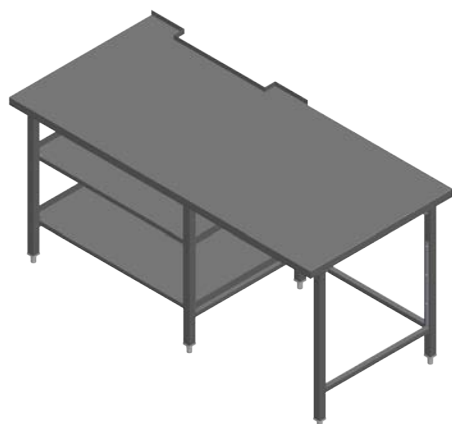
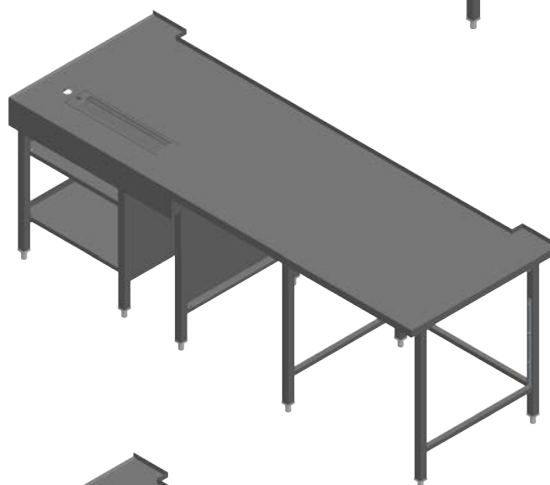
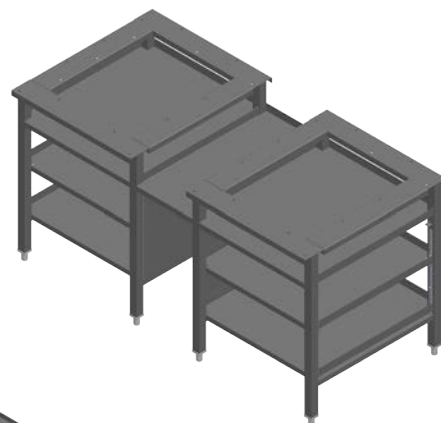

THE PINNACLE OF PRODUCTIVITY

All SPG prep stations and work centers are ergonomically designed to put tools and supplies within easy reach of your staff...deliver maximum storage...feature large work surfaces...and maximize the productivity of your operation.



ISS™ 72-In. Prep Station

- Combines strength and durability with the ultimate in accessibility and ergonomic design
- 18" deep wire and stainless steel shelves, 30" x 66" stainless countertop and channel dunnage shelf
- Accessories include grid baskets, scoop holder, pot hook and more
- Gold Bond® finish for years of durable service

Model No.	W x L x H		Weight	
	(In.)	(mm.)	(Lbs.)	(Kg)
10172MB	30 x 72 x 86	762 x 1828 x 2184	395	179

For an assembled unit, add "A" as suffix to the model no.



ISS™ Work Center III

- Choose from a wide array of posts, shelves, shelf covers and accessories
- Supports up to 1,250 lbs.
- Plating Plus™, Grey Bond® or Gold Bond® finish

Model No.	W x L x H		Weight	
	(In.)	(mm.)	(Lbs.)	(Kg)
WKIII548Y	24 x 48 x 78.5	610 x 1219 x 1994	136	62

Call your SPG representative to customize a work center solution for your operation.



Universal® Stainless Prep/Bakery Finishing Table

- High efficiency design for high-volume operations
- 16-ga. 300 Series stainless steel
- Overshelf keeps supplies and utensils at hand
- Easy-to-clean stainless back and side splashes
- C-channel reinforcement for strength & stability
- Sturdy H-frame legs are made of 1-5/8" dia. stainless steel tubing with adjustable rear cross-rail
- Unit ships unassembled for reduced freight and quick set-up

Model No.	W x L x H		Weight	
	(In.)	(mm.)	(Lbs.)	(Kg)
D0-45LCB6	48 x 36 x 34	1220 x 915 x 863	167	77





Universal® Stainless Mixer Stand

- Heavy-duty 16-ga. 300 Series stainless steel top
- Legs are made of 1-5/8" O.D. stainless steel tubing with adjustable bullet feet
- Undershef: 18-ga. stainless steel, notched to fit legs and fully welded
- Raised marine edge to contain equipment

Model No.	W x L		Cubic Feet		
	(In.)	(mm.)	(Lbs)	(Kg.)	
MS-30-S	30 x 30	762 x 762	65	30	18

Also available in additional sizes, galvanized steel and with a Utensil Tree option, call for details.

Kelmax Mobile Grill Stand



- All-aluminum construction designed to hold most countertop cooking equipment
- 24" and 30" deep tops with three 1-1/2" lips up on three sides: 24" high
- Bottom shelf is standard for increased storage capacity
- Ships knockdown, sets up easily with an allen wrench

Model No.	D x W x L		Weight	
	(In.)	(mm.)	(Lbs)	(Kg.)
4H0114	24.5 x 36.5 x 24	622 x 927 x 610	35	16
4H0118	24.5 x 48.5 x 24	622 x 1232 x 610	40	18
4H0122	24.5 x 60.5 x 24	622 x 1537 x 610	45	20
4H0131	30.5 x 36.5 x 24	775 x 927 x 610	40	18
4H0135	30.5 x 48.5 x 24	775 x 1232 x 610	45	20
4H0140	30.5 x 60.5 x 24	775 x 1537 x 610	50	23

Also available as stationary units

The Essentials Of An Efficient Workplace.

SPG products are designed to maximize speed and efficiency — and they're built to exacting standards with the highest quality materials for years of durable, dependable service and long-term economy. They all work together to create a highly productive workplace, and are available through one convenient and reliable source: your SPG sales representative.



SPG's foodservice products are all manufactured to meet NSF standards. For specific items, visit www.nsf.org

Universal® Stainless Custom Dish Tables

SPG can customize a dish table system that fits both your space and your needs. Universal® Stainless custom dish tables are:

- Fabricated entirely from high-quality 16 or 14-ga. 300 Series stainless steel
- Built to your precise specifications
- Available with a complete line of standard accessories, including scrap blocks, scrap baskets, racks, troughs and sink covers

Contact your SPG rep for details.
Check out our dish table accessories on page 77.

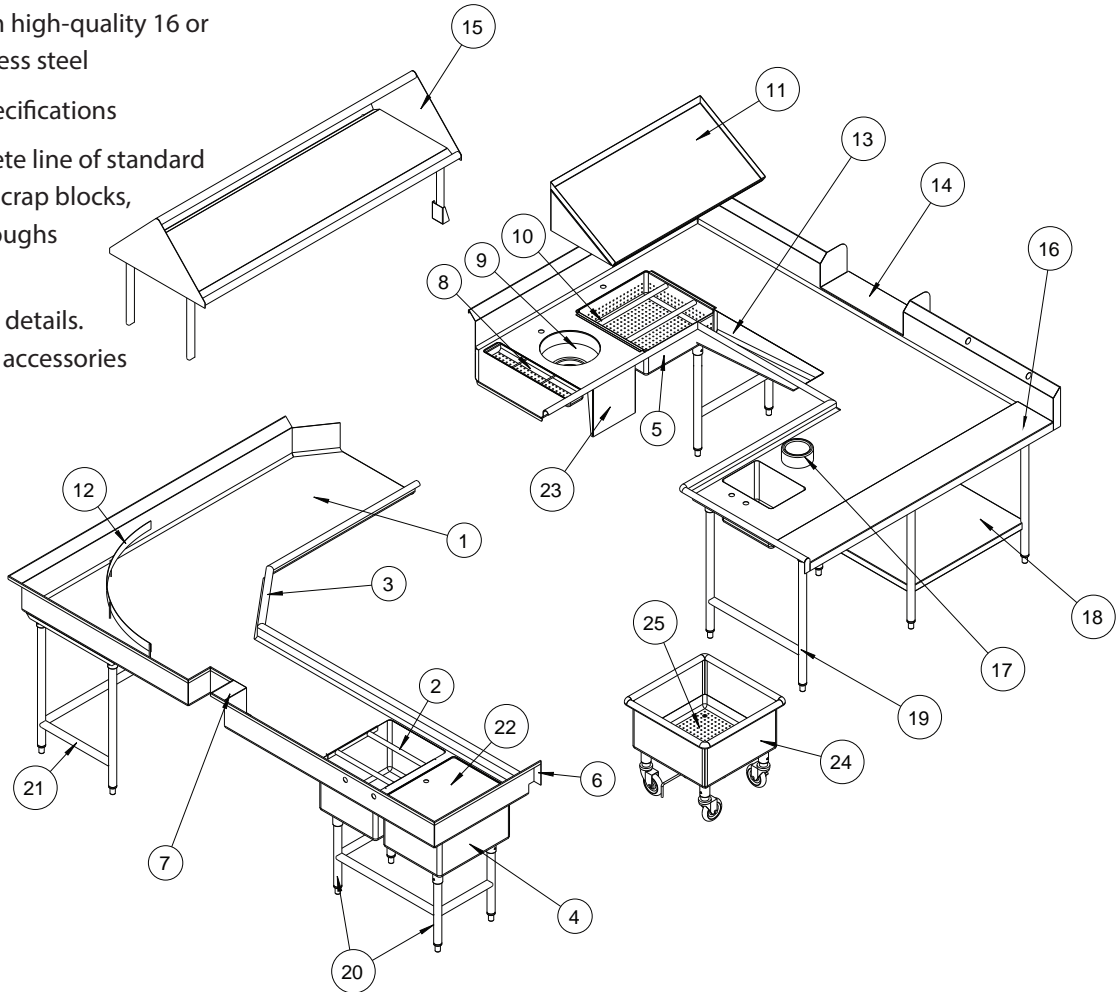

Number	Description	Qty.
1	30" Wide Dish Table Top For wider tables contact factory	Lin. Ft.
2	Stainless Steel Rack Slide	Each
3	Mitre-Rolled Edge	Each
4	Custom fabricated sink bowls available in a variety of sizes. Contact factory.	Each
5	Pre-Rinse Sink Bowl 20" x 20" x 8"	Each
6	End Splash-9"	Each
7	Notch in Backsplash	Each
8	Quick Drain Trough with Scrap Basket	Each
9	Cone Weldment (Cone by Others) Collar Weldment (Collar by Others)	Each Each
10	Stainless Steel Scrap Basket with Slides	Each
11	Slant Rack Shelf- Wall Mounted Slant Rack Shelf- Cantilevered	Lin. Ft. Lin. Ft.

Number	Description	Qty.
12	Curved Rack Glide- Stainless Steel	Each
13	Tapered Scrap Trough	Lin. Ft.
14	Pass through Window Ledge	Lin. Ft.
15	Double Rack Shelf	Lin. Ft.
16	Landing Ledge	Lin. Ft.
17	Rubber Scrap Block Die Raised Scrap Block Hole	Each Each
18	Stainless Steel Fixed Undershef- 18 Gauge, Includes legs	Lin. Ft.
19	Stainless Steel H-Frame Legs	Each
20	Stainless Steel Legs and Feet- must specify Lgth.	Each
21	Stainless Steel Horizontal Crossrail to 72" max	Each
22	Sink Cover	Each
23	Disposer Switch Bracket Disposer Control Panel Bracket	Each Each
24	Mobile Soak Sink (with casters & lever drain)	Each
25	Perforated Scrap Basket	Each
26	14 Gauge Stainless Steel Available	—

Universal® Stainless Clean And Soiled Dish Tables

- 16-ga. 300 Series stainless steel tops and bowls
- 5/8" radius on all corners for greater ease of cleaning
- Sanitary 180 degree rolled edges at free sides
- Stainless steel under bracing locations provide solid top and minimal deflection
- Units ship with stainless steel H-frame legs off reducing freight and allowing quick assembly
- Units are available in "Left" or "Right" side configurations



Universal® Stainless Soiled Dish Table

- Standard with 20" x 20" x 6" pre-rinse bowl
- Bowl fully fabricated for full metal thickness and added strength throughout

Model No.	Length (In.)	Length (mm.)	Weight (Lbs)	Weight (Kg.)	Cubic Feet
SDT-6-L	72	1829	120	55	28

Also available:
 In lengths from 48 to 84 inches
 In L shape and corner configurations
 With 14-ga. 300 Series stainless steel tops and bowls



SPG's foodservice products are all manufactured to meet NSF standards. For specific items, visit www.nsf.org

Universal® Stainless Clean Dish Table

Model No.	Length (In.)	Length (mm.)	Weight (Lbs)	Weight (Kg.)	Cubic Feet
CDT-3-R	36	914	40	18	9

Also available: In lengths from 36 to 72 inches
 In L shape and corner configurations
 With 14-ga. 300 Series stainless steel tops and bowls

Universal® Stainless Economy Line Enclosed Base Tables

- Top 16-ga. 300 Series stainless steel
- Body and shelves are made of 18-ga. 430 Series stainless steel
- Rear and side panels die formed and welded to legs for rigidity
- Undershelf die formed and welded to rear and side panels
- Legs: 1-1/2" stainless steel square tubing with adjustable bullet feet
- Backsplash: 6" high including 2" return at 45 degree angle with ends closed
- Doors: single pan construction, suspended with overhead track, ball bearing rollers with recessed pulls
- 36" height

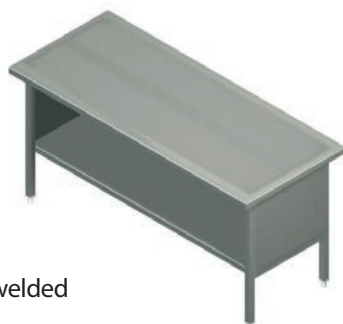

Model No.	W x L	Weight(Lbs.)
Open Front With Flat Top		
4EET-30	30 x 48	125
Available in 24" & 30" depths, 48" - 120" lengths		
Open Front With 6" Backsplash		
4EET-30B	30 x 48	131
Available in 24" & 30" depths, 48" - 120" lengths		
Flat Top With Sliding Doors		
4EET-30D	30 x 48	150
Available in 24" & 30" depths, 48" - 120" lengths		
6" Backsplash With Sliding Doors		
4EET-30BD	30 x 48	156
Available in 24" & 30" depths, 48" - 120" lengths		

TABLES

Universal® Stainless Work Table

- Choose from two series of tables:
Standard N Series: 16-gauge 300 Series stainless steel top
Spec SL Line: 14-gauge 300 Series stainless steel top
- Configurations include:
Galvanized or stainless steel legs and crossrails
Flat top or 6" backsplash
With or without undershelf
- Tops braced with heavy gauge galvanized hat channels and sound deadened
- Square edge design for clean abutment to other equipment
- Underbracing locations provide solid top and minimal deflection
- Legs: 1-5/8" O.D. 16-gauge stainless steel or galvanized tubing with adjustable bullet feet and stainless steel gussets
- Crossrails: 1-5/8" O.D. 16-gauge stainless steel or galvanized tubing, notched to fit legs and fully welded
- Undershelves: 18-gauge stainless steel or galvanized with corners notched to fit legs and fully welded
- Standard working height is 36"
- All tables 84" and longer come standard with 6 legs
- Ships welded and set up - no assembly required

Table Options

Model No.	Description	Qty.
TAC-5	End Splash	Each
TAC-5-24	Cap & Finish for End Splash*	Each
TAC-5-30	Cap & Finish for End Splash*	Each
TAC-6	Splash Cut-Out	Each
TAC-7	Step Down in Top	Each
TAC-8	Urn Trough	Linear Ft.
TAC-9A	Table Cut-Out less than 6"	Each
TAC-9B	Table-Cut Out up to 20"	Each
TAC-9C	Table-Cut Out over 20" x 20"	Each
TAC-10	Receptacle Box MTD in Splash	Each
TAC-ME	Marine Edge	Linear Ft.
TAC-RE	Rolled Edge	Linear Ft.
TAC-IVE	Inverted "V"	Linear Ft.

*Does not include End Splash



Model No.	W x L	Gauge of Top	Weight(Lbs.)
Flat Top With Galvanized Legs & Crossrails			
4GLC-30	30 x 48	16 GA	100
4-SL-GLC-30	30 x 48	14 GA	120
Available in: 24" & 30" depths, 36", 48", 60" & 72" lengths			
Flat Top With Galvanized Legs & Undershelf			
4GLS-30	30 x 48	16 GA	120
4-SL-GLS-30	30 x 48	14 GA	132
Available in: 24" & 30" depths, 36", 48", 60" & 72" lengths			
6" Backsplash With Galvanized Legs & Crossrails			
4GLCB-30	30 x 48	16 GA	115
4-SL-GLCB-30	30 x 48	14 GA	130
Available in: 24" & 30" depths, 36", 48", 60" & 72" lengths			
6" Backsplash With Galvanized Legs & Crossrails			
4GLSB-30	30 x 48	16 GA	130
4-SL-GLSB-30	30 x 48	14 GA	143
Available in: 24" & 30" depths, 36", 48", 60" & 72" lengths			
Flat Top With Stainless Steel Legs & Crossrails			
4SLC-30	30 x 48	16 GA	100
4-SL-SLC-30	30 x 48	14 GA	120
Available in: 24", 30" & 36" depths, 24" – 108" lengths			
Flat Top With Stainless Steel Legs & Undershelf			
4SLS-30	30 x 48	16 GA	120
4-SL-SLS-30	30 x 48	14 GA	120
Available in: 24", 30" & 36" depths, 24" – 108" lengths			
6" Backsplash With Stainless Steel Legs & Crossrails			
4SLCB-30	30 x 48	16 GA	115
4-SL-SLCB-30	30 x 48	14 GA	135
Available in: 24", 30" & 36" depths, 24" – 108" lengths			
6" Backsplash With Stainless Steel Legs & Undershelf			
4SLSB-30	30 x 48	16 GA	130
4-SL-SLSB-30	30 x 48	14 GA	150
Available in: 24", 30" & 36" depths, 24" – 108" lengths			

See additional table options on pages 78 and 79.



SPG's foodservice products are all manufactured to meet NSF standards. For specific items, visit www.nsf.org

Universal® Stainless Cabinet Base Tables

Model No.	W x L	Weight(Lbs.)
Open Front With Flat Top		
4CBT-30	30 x 48	125
Available in 24" & 30" depths, 48" – 120" lengths		
Open Front With 6" Backsplash		
4CBT-30B	30 x 48	131
Available in 24" & 30" depths, 48" – 120" lengths		
Flat Top With Sliding Doors		
4CBT-30D	30 x 48	150
Available in 24" & 30" depths, 48" – 120" lengths		
6" Backsplash With Sliding Doors		
4CBT-30BD	30 x 48	156
Available in 24" & 30" depths, 48" – 120" lengths		
Flat Top With Hinged Doors		
4CBT-30HD	30 x 48	150
Available in 24" & 30" depths, 48" – 120" lengths		
6 Backsplash With Hinged Doors		
4CBT-30BHD	30 x 48	156
Available in 24" & 30" depths, 48" – 120" lengths		

- Choose from open-front, sliding or hinged doors; flat top and 6" backsplash
- Includes one mid shelf
- Uni-body design includes die-formed rear and end panels welded to undershelves to achieve rigid one-piece unit
- Top 16-ga. 300 Series stainless steel — body and shelves are 18-ga. 300 Series stainless steel
- Legs: 6" high stainless steel with adjustable bullet feet
- Doors (if applicable) double pan, die formed and suspended with overhead track and ball bearing rollers with recessed pulls



Universal® Stainless Poly Top Tables



- Table frame fabricated from 1-1/2" square 16-ga. 300 Series stainless steel tubing
- Base fully-welded 1-5/8" stainless steel tubing legs and crossrails with stainless steel adjustable bullet feet
- 5/8" thick poly tops are sectional and removable per NSF standard No. 2 — and made of NSF and USDA approved high density polyethylene
- 6" backsplash and deck formed from one-piece stainless steel and welded
- Crossrails are 1-5/8" O.D. stainless steel tubing notched to fit legs and fully welded
- Underself is 18-ga. stainless steel with corners notched to fit legs and fully welded
- Ships fully welded and set up

Model No.	W x L	Weight(Lbs.)
Flat Top With Stainless Steel Legs & Crossrails		
4MCT-30	30 x 48	95
Available in: 30" depth, 48" – 120" lengths		
Flat Top With Stainless Steel Legs & Underself		
4MCT-30U	30 x 48	125
Available in: 30" depth, 48" – 120" lengths		
6" Backsplash With Stainless Steel Legs & Crossrails		
4MCT-B30	30 x 48	95
Available in: 30" depth, 48" – 120" lengths		
6" Backsplash With Stainless Steel Legs & Underself		
4MCT-B30U	30 x 48	125
Available in: 30" depth, 48" – 120" lengths		

UNIVERSAL UTILITY

Universal® Stainless sinks are available in a huge variety of sizes and configurations — from mobile sinks to hand sinks to compartment sinks with one to four bowls. Manufactured to fit any space ... accessories to satisfy every operational need.



Universal® Stainless Mobile Hand Sink

This is a complete, totally self-contained unit, requiring only a 110V/20-amp power source to operate.

- Promotes food safety, staff hygiene, adherence to HACCP principles
- A spacious 26" x 24" x 36" cabinet base with a 16-ga. stainless steel top and 18-ga. body
- 8" back and side splashes
- Four locking casters to provide mobility
- Powerful 115V UL listed water pump
- Mini™ 2 at 110V/15 amp tankless in-line water heater
- A faucet that blends hot and cold water
- 110° F water supplied at .32 GPM
- Paper towel holder and soap dispenser
- 5-gallon clean tank plus a 6-gallon waste tank
- 10' cord with GFI plug to wall/power source
- Optional end splashes available, contact your rep



Model No.	W x L x H (In.)	W x L x H (mm.)	W x L x H (Lbs.)	(Kg)
KAMTS-2624-36	26 x 24 x 36	660 x 610 x 914	190	86

Universal® Stainless Hand Sinks

- Choose from Standard Series (18-ga. deep fully fabricated bowl) or Spec Series (16-ga. 300 Series stainless steel, fully fabricated)
- 12" x 10" x 6" (305 x 254 x 152) bowl size
- 7" high integrally formed backsplash
- Inverted "V" non-drip edge on three sides
- Includes faucets, basket drains, and wall brackets



Model No.	Bowl Size L x W x D (In.)	Bowl Size L x W x D (mm.)	Weight (Lbs.)	Weight (Kg.)	Cubic Feet
Drop In Hand Sinks With Faucets & Basket Drain					
DI-1-5DF	10 x 14 x 5	254 x 356 x 127	8	4	0.6
DI-1-10DF	10 x 14 x 10	254 x 356 x 254	10	5	1.0
Skirted Hand Sinks					
EHS-2	12 x 10 x 6	305 x 254 x 152	20	9	2.5
Hand Sink With Soap & Towel Dispensers					
EHS-3	12 x 10 x 6	305 x 254 x 152	27	12	2.5
Hand Sink With Soap & Towel Dispensers Below					
CHS-5	12 x 10 x 6	305 x 254 x 152	36	16	4
ADA Compliant Hand Sink With Handles & Soap Dispenser					
HS-ADA	16 x 17 x 6	406 x 432 x 152	20	9	2.5

Universal® Stainless 3-Compartment Sink With 2 Drainboards

- Available in 16-ga. (N Series) or 14-ga. (SL-Series) 300 Series stainless steel construction
- Fully fabricated bowl with full metal thickness throughout for greater strength than a drawn sink
- 9" high integrally formed backsplash, with 2" return to wall at 45°
- 2 -1/2" high, 180° sanitary rolled rim at all free edges
- Leg assemblies are located directly under sink bowls for greater load support
- Legs are 1-5/8" diameter tubing with adjustable bullet feet
- N-Series have galvanized legs; SL-Series feature stainless steel legs and crossrails
- Where applicable, crossrails are 1-5/8" diameter — coped and fully welded for maximum durability
- All corners are covered at 5/8" radius, welded and polished to form a one-piece sanitary unit
- Comes with basket drains and 1-1/8" faucet holes punched in backsplash on 8" centers as required
- NSF listed and CSA certified



SPG's foodservice products are all manufactured to meet NSF standards. For specific items, visit www.nsf.org



Check our Wall Trax™ system on page 30!

Model No.	Approx. Weight			Drainboard		L x W	
	(Lbs.)	(Kg.)	(Cu. Ft.)	(In.)	(mm.)	(In.)	(mm.)
3SL1824-2D18	196	89	53	18	457	94 x 29.5	2388 x 749
3N1824-2D18	172	78	49	18	457	94 x 29.5	2388 x 749

SPG has a full range of 1, 2 and 3-compartment sinks — with bowl sizes from 16" x 18" to 30" x 30" and a variety of drainboard options. 4-compartment sinks and custom bowl sizes are available, call for details.

Universal® Stainless Standard And Anti-Splash Floor Troughs

- 14-ga. 300 Series stainless steel subway grating
- Stainless steel waste cup up to 3" waste pipe
- Includes 3 O.D. - 4" long plumbing sleeve

Universal® Stainless offers: A choice of stainless steel subway grating or Fiberglass grating — with or without anti-splash feature.

Three widths (12", 18", & 24") and lengths from two feet to five feet in six-inch increments.

Call for details.

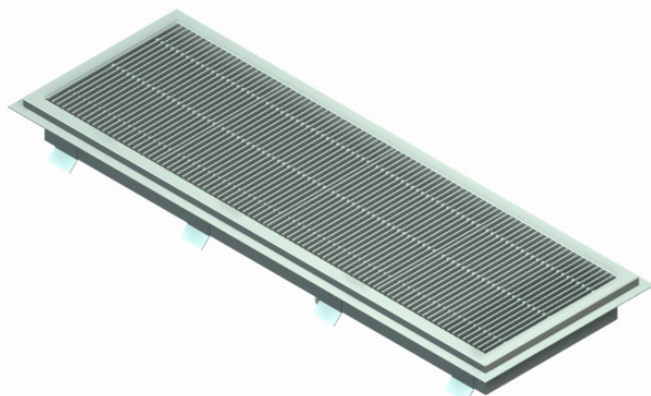

STRONG STUFF.

Universal® Stainless bar equipment employs 16-ga. 300 Series stainless steel to provide greater durability than competitive equipment — even the legs on our equipment are stainless.



Universal® Stainless Cocktail Stations

- Ice bin: 2" insulation on bottom; 1" on sides
- Includes 6 bottle wells for speedy service



Model No.	Bowl Depth		L x W x H		Weight		
	(In.)	(mm.)	(In.)	(mm.)	(Lbs.)	(Kg.)	(Cu. Ft.)
DLCS-24	8	203	24 x 20 x 29	610 x 508 x 737	45	20	6
DLCS-24 -8C	(Features an additional 8 circuit sealed-in cold plate)						

Universal® Stainless 3-Bowl Underbar Sink

- All welded construction for strength
- Front and side marine edges eliminate dripping
- 4" backsplash and basket-type waste drains
- Faucets and overflow tubes included



Model No.	Bowl Size		Length		Drainboard Size		Weight		
	(In.)	(mm.)	(In.)	(mm.)	(In.)	(mm.)	(Lbs.)	(Kg.)	(Cu. Ft.)
DL3-60-2D12	10 x 14 x 10	254 x 356 x 254	60	1524	12	305	85	39	14.0



Universal® Stainless Drainboards

- 4" integrally formed backsplash
- One-piece die formed top
- Surface embossed and raised for efficient drainage
- 1" brass waste drain included

Model No.	L x W		Weight		
	(In.)	(mm.)	(Lbs.)	(Kg.)	(Cu. Ft.)
DLDB-36	36 x 20	914 x 508	40	18	8



SPG's foodservice products are all manufactured to meet NSF standards. For specific items, visit www.nsf.org



Universal® Stainless Bottle Display Unit

- Plenty of storage in 3 tiers
- Bottle rails made of 1/2" stainless steel round bars
- Solid bottle ledges, easily accessible for cleaning

Model No.	L x W		Weight		
	(In.)	(mm.)	(Lbs.)	(Kg.)	(Cu. Ft.)
DLBD-36	36 x 20	914 x 508	85	39	9

For a complete selection of under-counter bar equipment, please contact SPG customer service

Kelmax Beverage Bucket

- Perfect for soft drinks, beer and wine
- Great for point of purchase displays
- Holds 24 (20 oz.) bottles
- Urethane foam insulation keeps contents cold while reducing ice consumption
- Twin handles make transporting easy



Model No.	W x L x H		W x L x H	
	(In.)	(mm.)	(Lbs.)	(Kg)
4K0917	19 x 12 x 9	483 x 305 x 229	7	3



Kelmax Keg Storage Racks

- Organize inventory and optimize keg storage space
- Keep kegs off the floor to reduce the chance for damage
- Heavy-duty 1-1/2" x 2" tubular frame
- "E" channel laterals run front to back to allow sliding of kegs
- All-welded aluminum construction
- Lifetime guarantee against rust

Model No.	Keg Capacity	W x L x H		Weight	
		(In.)	(mm.)	(Lbs.)	(Kg.)
4H2255	4	17 x 42 x 76	432 x 1067 x 1990	46	21
4H2262	6	17 x 60 x 76	432 x 1524 x 1990	52	23.5
4H2271	8	17 x 80 x 76	432 x 2032 x 1990	62	28
4H2249	10	17 x 93 x 76	432 x 2362 x 1990	48	35.5



AMCO® Bulk Storage Wine Racks

- Comprised of 3 shelves, 4 posts and wine modules
- Wall bracket secures top shelf to wall for stability

Model No.	Bottle Capacity	W x L x H		Weight	
		(In.)	(mm.)	(Lbs.)	(Kg.)
783	192	12 x 48 x 64	305 x 1220 x 1625	94	42
785	216	12 x 48 x 72	305 x 1220 x 1830	100	45.5
789	240	12 x 48 x 84	305 x 1220 x 2130	108	49

STAFF SUPPORT

For the backroom, SPG offers the safety of heavy-duty ladders, the security of employee lockers, a wide selection of essential equipment...and a single source for all your operational needs.



Gillis All-Welded Step Ladders

- Solid steel rubber covered steps
- 55 degree climb angle
- 10" deep top step — other steps 7" deep
- Beige unless specified — gray-blue available
- 16" wide steps
- 20" top step available
- Available with handrail option



Model No.	No. Steps	Platform Height (In.)	Handrail Height (In.)	Overall Height (In.)	Base W x L (In.)	Weight (Lbs.)
No Handrail - All Welded (set up)		4-3" Retractable Spring Casters				
F1N1*	1	13	N/A	13	20 x 16	14
F2N1*	2	20	N/A	20	21 x 20	20
F3N1	3	30	N/A	30	21 x 29	26
F4N1	4	40	N/A	40	21 x 36	33
With Handrail - All Welded (set up)		4-3" Retractable Spring Casters				
F2R1	2	20	24	53	21 x 20	30
F3R1	3	30	24	63	21 x 29	36
F4R1	4	40	30	73	21 x 36	50
F5R1	5	50	30	83	21 x 44	54

*Ships UPS boxed with no extra packaging charges. Others ship on a pallet at no additional charge.

Kelmax Lockers

- Heavy-duty steel construction — including 16-ga. doors and frames
- Durable powder coated beige finish is standard. Other colors available subject to availability and lead times
- Padlock hasps are standard on all units for locking

Model No.	D x L x H (In.)	Weight (Lbs.)
Two-Door Lockers		
4K0034	15 x 12 x 78	74
4K0029	18 x 12 x 78	78
Three-Door Lockers		
4K1316	15 x 12 x 78	78
4K0052	18 x 12 x 78	80
Five-Door Lockers		
4K0071	12 x 12 x 66	78
4K0129	15 x 12 x 66	84
Six-Door Lockers		
4K0090	12 x 12 x 78	78
4K0091	15 x 12 x 78	85
4K0094	18 x 12 x 78	88

Scan here to see our complete line of Kelmax lockers and options



AMCO® Coat Rack



- Plating Plus™ — zinc plating and chromate seal with a clear lacquer form a durable, hard-as-nails finish
- Bottom shelf, coat rod hanger and two upper shelves

Model No.	W x L x H		Weight	
	(In.)	(mm)	(Lbs.)	(Kg.)
CR246084CP	24 x 60 x 84	610 x 1525 x 2130	129	58.5

Other sizes available, call for details.



SPG's foodservice products are all manufactured to meet NSF standards. For specific items, visit www.nsf.org

Kelmax Receiving Desk



- Durable all steel construction
- Lockable storage area
- Gray powder-coated finish

Model No.	W x L x H		Approx. Weight	
	(In.)	(mm.)	(Lbs.)	(Kg.)
Stationary Unit				
4G0186	24 x 24 x 48	610 x 610 x 1229	45	20
Mobile Unit				
4G0183	24 x 24 x 51	610 x 610 x 1295	51	23

Kelmax receiving desks are available in a variety of sizes and in stationary, mobile, enclosed, open and wall mount models — call for details.



Discover Our Material Handling and Industrial Storage Products — And A Whole New Side Of SPG.

If your operation includes warehousing, processing or distribution facilities, you'll find SPG offers a broad selection of high-quality material handling products. You'll find everything from industrial carts, racks and shelving to protective rail system, ladders and platforms in the SPG Material Handling and Industrial Storage Solutions catalog at spgusa.com.

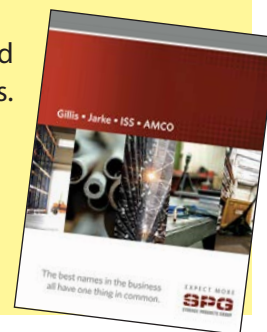

Scan to see our Material Handling Catalog



ACCESSORIES

Everything you need to create a customized solution.

On the following pages you'll find an array of accessories to help make your workplace more efficient, productive and organized... to add strength and increase the durability of your equipment... and to maximize your space, return on investment and the profitability of your entire operation.



AMCO® Accessories

AMCO® Compartmented Wine Modules

Plating Plus™ Model No.	(In.)	W x L x H (mm.)	Bottle Capacity	(Lbs.)	(Kg.)
710	8 x 21.5 x 26.5	213 x 546 x 673	48	9	4
711	8 x 21.5 x 34.5	213 x 546 x 876	60	11	5



Fastens to shelves or countertop

AMCO® 3-Sided Frames

Model No.	(In.)	(mm.)	(Lbs.)	(Kg.)
TTF1836	18 x 36	455 x 915	4	2
TTF1848	18 x 48	455 x 1220	5	2
TTF1860	18 x 60	455 x 1525	6	3
TTF2436	24 x 36	610 x 915	6	3
TTF2448	24 x 48	610 x 1220	7	3
TTF2460	24 x 60	610 x 1525	8	4



To ensure stability for stationary shelving units, the bottom shelf should always be installed at the lowest position. When storage demands require the lowest shelf to be installed at 24" (610mm) or more above the floor it is recommended that a support frame be used.

AMCOAT® Shelf Covers

- Rugged polyethylene plastic shelf cover keeps liquids, crumbs and dirt from dropping to shelves below
- Promotes air circulation in walk-in refrigerators and freezers
- Prevents moisture accumulation

Model No.	L x W (In.)	(mm.)	Weight (Lbs.)	(Kg.)
AM1836P	18 x 36	457 x 914	1.5	1
AM1848P	18 x 48	457 x 1219	2	1
AM1860P	18 x 60	457 x 1524	2.5	1
AM2436P	24 x 36	610 x 914	2	1
AM2448P	24 x 48	610 x 1219	3	1
AM2460P	24 x 60	610 x 1524	3.5	1.5



Add-On Clips

- Creates continuous runs of wire shelving — use two on each side of shelf where two posts are not used



Model No. AOCLIPCP

Plastic Plus® Add-On & Corner Clips

- Use Add-On clips to extend the shelf run
- Use Corner Clips when the shelving unit will be placed at 90 degrees to the starter unit



Model No.	Description
PP180	Add-On Clip
PP90	Corner Clip

Shelf Hooks

- Stainless steel — for hanging accessories and tools from wire shelves or utility rails



Model No. HOOKS

Utility Rails

- Channel rails for hanging tools or accessory baskets
- Hang items directly with Shelf Hooks (HOOKS)



Model No.	L x W (In.) (mm.)	Weight (Lbs.) (Kg.)
AR24CP	24 610	2.5 1
AR48CP	48 1219	4 2

Stacking Basket Components

- Baskets, dividers & dollies sold separately for customization
- Baskets can be wall mounted — wall bracket included

Model No.	W x L x H (In.)	W x L x H (mm.)	Weight (Lbs.) (Kg.)
ASB1648GR	16 x 48 x 9	406 x 1219 x 235	10 4.5
ASB1824GR	18 x 24 x 9	457 x 610 x 235	7 3.2
ASB2024GR	20 x 24 x 9	508 x 610 x 235	7 3.2



Tray Slides

- 12 tray capacity — great for taking advantage of the space above wire shelves to store bun pans or trays
- For 18", 21" and 24" wide shelving



Plating Plus™ Model No.	Polygard® Model No.	W x H (In.) (mm.)	Weight (Lbs.) (Kg.)
ASB1648GR	ATS18PG	13.5 x 22 340 x 552	10.5 5

AMCO® Collets



Model No.	Description
COLZ	Collets Set of 4 Square Plastic



SPG's foodservice products are all manufactured to meet NSF standards. For specific items, visit www.nsf.org

Shelf Inlays

- Add a solid work surface to your shelving unit

Model No.	W x L (In.) (mm.)		Weight (Lbs.)
BIL1224BK	12 x 24	305 x 610	.75
BIL1230BK	12 x 30	305 x 762	1
BIL1236BK	12 x 36	305 x 914	1.5
BIL1436BK	14 x 36	355 x 914	3
BIL1836BK	18 x 36	457 x 914	1
BIL1848BK	18 x 48	457 x 1219	2
BIL1860BK	18 x 60	457 x 1524	2
BIL2448BK	24 x 48	610 x 1219	3



Plastic Plus® and New Era™ Label Holder

- Slotted snap-on grey label holder for paper inserts — fits all shelf lengths

Model No.	Length (In.)	For Labels (In.)
LP603	3	1 x 3

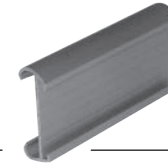

Label Holders for New Era™, Solid Stainless Steel, Wire, Plasteel® and Dunnage Shelves

- Slotted — affixes to shelf with self-adhesive strip
- Insert paper label from side
- Available in grey only



Length Model No.	Length (In.)	Fits Shelf Length (In.)	For Labels W x L (In.)
SHLAB	6	All	.75 x 6

Clear Covered Label Holder

- Insert paper label from side
- Label is protected by clear plastic face



Model No.	Length (In.)	Fits Shelf Width (In.)	For Labels W x L (In.)
SHLAB2	5.5	All	1 x 5.5
SHLAB3	3	All	1 x 3

Shelf Ledges

Model No.	Fits Shelf Length (In.)	Weight (Lb.)
LU12	12	.5
LU18	18	.5
LU21	21	.75
LU24	24	1
LU30	30	1.5
LU36	36	1.5
LU42	42	2
LU48	48	2
LU54	54	2
LU60	60	2.5
LU72	72	3

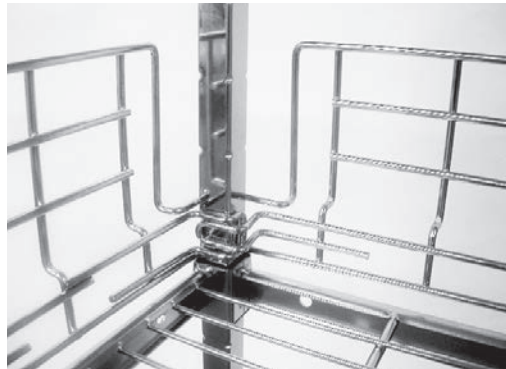

AMCO® Shelf Ledges

- 6" high ledges mount to shelf posts to keep goods from falling off the back or sides of shelves
- Use with all styles of shelves
- Can be stacked on top of each other for additional height — or mounted below shelves to reduce height

Plastic Plus® Enclosure Panels

Model No.	Type	W x L		Weight	
		(In.)	(mm.)	(Lb.)	(Lb.)
PPEP1864GRX	Side Panel	18 x 64	455 x 1625	8	4
PPEP2464GRX	Side Panel	24 x 64	610 x 1625	10	4.5
PPEP3664GRX	Back Panel	36 x 64	915 x 1625	18	8
PPEP4864GRX	Back Panel	48 x 64	1220 x 1625	22	10
PPEP6064GRX	Back Panel	60 x 64	1525 x 1625	27	12



Shelf Dividers

- Maintain separation of goods on wire shelves
- Order by shelf width
- Height: 8"



Model No.*	Length (In.)	Fits Shelf Length (In.)	Weight (Lb.)
SDU12	11	12	1
SDU18	17	18	1
SDU21	20	21	1.5
SDU24	23	24	2

*Add suffix C to Model No. for Plating Plus™, add PG for Polygard® (Blue) finish.

Plastic Plus® and New Era™ Shelf Dividers

Model No.*	W x H (In.)	Fits Shelf (In.)
PPSD18P	18 x 4	18
PPSD24P	24 x 4	24



SPG's foodservice products are all manufactured to meet NSF standards. For specific items, visit www.nsf.org

Tray Modules

- Holds serving trays and insulated feeding trays for drying and storage
- Includes clips for easy attachment to shelves

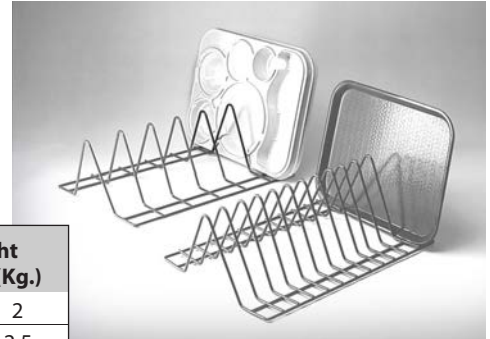

Polygard® Model No.	Spacing		Tray Cap.	W x L x H		Weight	
	(In.)	(mm.)		(In.)	(mm.)	(Lbs.)	(Kg.)
TM181PG	2	44	8	15.5 x 16.5 x 8	394 x 419 x 203	4	2
TM241PG	2	40	12	15.5 x 22.5 x 8	394 x 572 x 203	5.5	2.5
TM181PG	3	81	4	15.5 x 16.5 x 8	394 x 419 x 203	3	1
TM181PG	3	87	6	15.5 x 22.5 x 8	394 x 572 x 203	4	2

Jumbo Tray Storage Module

- Great for large tray storage demands
- Has 35 tray slides
- Two smaller trays can be stored in each slide to deliver an enormous 70-tray capacity in 48"
- Modules fit the channels of 24" x 48" shelves

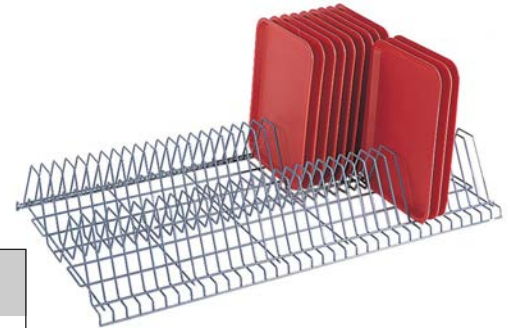

Gray Epoxy Model No.	Spacing (In.)	Spacing (mm.)	Tray Capacity (Lbs.)	W x L x H (In.)	W x L x H (mm.)	Weight (Lbs.)	Weight (Kg.)
TM12448GRX	1	25	35	24.5 x 45 x 5	616 x 1143 x 135	22	10

Steam Table Pan Rack

- Use as stand alone on worktables or attach to wire shelves
- Ideal for reach-in or walk-in refrigerators
- Module has 8 slides 1-1/2" on center

Plating Plus™ Model No.	W x L x H (In.)	W x L x H (mm.)	Weight (Lbs.)	Weight (Kg.)
TSSTC	22 x 15 x 14	565 x 397 x 356	15	7



Universal Racks

- Accommodates full and half size sheet pans, 17-1/2" drawers, or a combination

Plating Plus™ Model No.	Gold Bond® Model No.	W x D x H		Fits Shelf (In.)	Accommodates	
		(In.)	(mm.)		# Pans	# Drawers
UNIV5TRC2	UNIV5TRY2	20 x 20.5 x 16	508 x 521 x 400	24	4	2
UNIV5TRC	UNIV5TRY	20 x 20.5 x 22	508 x 521 x 568	24	6	3

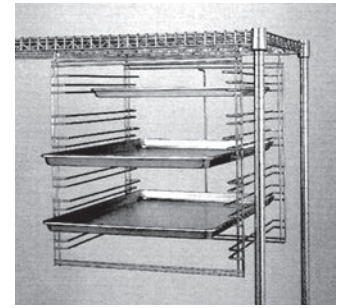

One Piece Undershelf Drawer Slides

- Accommodates 17-1/2" drawers

Plating Plus™ Model No.	Gold Bond® Model No.	W x D x H		Fits Shelf	
		(In.)	(mm.)	(In.)	(In.)
USS4C	USS4Y	22 x 18 x 11	558 x 457 x 279	21	533
USS5C	USS5Y	22 x 21 x 11	558 x 533 x 279	24	610



Adjustable Slide Kit

Plating Plus™ Model No.	Dimensions	
	(In.)	(mm.)
ADS24CKIT	24	610

2-Piece Tray Slides

Plating Plus™ Model No.	Gold Bond® Model No.	W x L x H		Slide Spacing		Fits Shelf	
		(In.)	(mm.)	(In.)	(mm.)	(In.)	(mm.)
TR3C	TR3Y	14.5 x 23	371 x 577	1.5	1	18	457
TR5C	TR5Y	20 x 23	508 x 577	1.5	1	24	610



ISS™ 3-Sided Frames

Gold Bond® Model No.	Grey Bond® Model No.	Plating Plus™ Model No.	Dimensions		Weight	
			(In.)	(mm.)	(Lbs.)	(Kg.)
TF336Y	TF336E	TF336C	18 x 36	457 x 914	8	3.5
TF348Y	TF348E	TF348C	18 x 48	457 x 1219	9	3.5
TF360Y	TF360E	TF360C	18 x 36	457 x 1524	11	3.5
TF536Y	TF536E	TF536C	24 x 36	610 x 914	8	3.5
TF548Y	TF548E	TF548C	24 x 48	610 x 1219	10.5	3.5
TF560Y	TF560E	TF560C	24 x 36	610 x 1524	11	3.5



To ensure stability for stationary shelving units, the bottom shelf should always be installed at the lowest position. When storage demands require the lowest shelf to be installed at 24" (610mm) or more above the floor it is recommended that a support frame be used.

Bins

- Attach to Hanger Bar or sit on shelf

Model No.	Color	L x W x H (In.) (mm.)	
ISS30230B	Blue	11 x 5.5 x 5	279 x 140 x 127
ISS30230BLK	Black	11 x 5.5 x 5	279 x 140 x 127
ISS30235B	Blue	11 x 11 x 5	279 x 279 x 127
ISS30235BLK	Black	11 x 11 x 5	279 x 279 x 127
ISS30240B	Blue	15 x 8 x 7	375 x 210 x 178
ISS30250B	Blue	15 x 16.5 x 7	375 x 419 x 178



Bin Divider

- Divides bin along width

Model No. ISS40120

Post Extender & Connector

- Joins two posts together for greater height

Model No.	Description
PE	Post Extender
PC	Post Connector



S-Hooks

- Use two S-Hooks per shelf to continue a run of shelving or in corners
- Provides easier access to corner storage by eliminating posts

Plating Plus™ Model No.	Gold Bond® Model No.	Stainless Steel Model No.
SH2C	SH2Y	SH2S



Corner Cap

- Covers shelf corners on add-on units or wall shelvings

Model No.: CHP1C Chrome Corner Cap
Model No.: CHP1Y Gold Bond® Corner Cap



Collar Plug

- Accessory plastic plug to cap wire shelf collars if desired when using wall brackets or add-on clips.

Model No. COLPL

Hanger Bar

- Bar fastens to posts to hold bins
- Available in Plating Plus™ and Gold Bond® finishes



Model No.	L x W x H (In.) (mm.)		Weight (Lb.) (Lb.)	
BH24E	1.5 x 24 x 3.5	38 x 610 x 89	1	0.3
BH36C	1.5 x 36 x 3.5	38 x 914 x 89	1	0.3
BH48Y	1.5 x 48 x 3.5	38 x 1219 x 89	1	0.3
BH60Y	1.5 x 60 x 3.5	38 x 1524 x 89	1	0.5

Coffee Pot Holders

Model No.	W x L x H (In.) (mm.)	Weight (Lbs.) (Kg.)
2-Pot Holder		
COFF2E	6 x 5 x 13 153 x 143 x 343	2.5 1
3-Pot Holder		
COFF3E	6 x 5 x 20.5 153 x 143 x 511	3 1

Drawer Dividers

Model No.	Description	Fits Drawers
DDL223	Long Drawer Divider	DO223
DDL173	Short Drawer Divider	DO223
DDL226	Long Drawer Divider	DO226
DDL176	Short Drawer Divider	DO226

Drawers

Model No.	W x L x H (In.) (mm.)	
DO223	3 x 22.5 x 17.5	76 x 558 x 457
DO226	6 x 22.5 x 17.5	152 x 558 x 457



Enclosure Panels

Model No*	H x W (In.) (mm.)		Weight (Lbs.) (Kg.)	
11" Width				
EP151	11 x 49	280 x 1244	5.5	2.5
EP159	11 x 57	280 x 1447	6	3
EP171	11 x 69	280 x 1752	7	3
15" Width				
EP254	15 x 49	381 x 1244	6	3
EP255	15 x 57	381 x 1447	7	3
EP271	15 x 69	381 x 1752	8	4
18" Width				
EP351	18 x 49	457 x 1244	8	4
EP359	18 x 57	457 x 1447	9.5	4
EP371	18 x 69	457 x 1752	10.5	5

*Select a finish. Add to model #

Finish	Use Suffix
Plating Plus™	C
Gold Bond®	Y



Perimeter Rod Kit

- Bar fastens to posts to hold bins
- Available in Plating Plus™ and Gold Bond® finishes

Plating Plus™ Model No.: EPC1C
Gold Bond® Model No.: EPC1Y

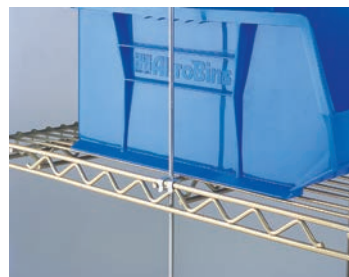

Clamps, Clips & Foot Plates

Model No.	Description	
PC2	Post Clamps	Joins 2 posts side x side
MFP1*	Modified Foot Plate	May Be Bolted To Floor
MMFP1*	Half Modified Foot Plate	May Be Bolted To Floor
FG4	Foot Glide	4 To Bag
WC1	Wall Clip	Secures Shelf To Wall (Not Illustrated)
WC2	Angled Wall Clip	Secures Shelf To wall

*Select a finish. Add to model #.

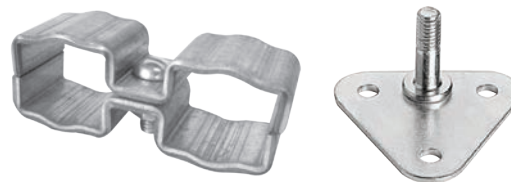

Finish	Use Suffix
Plating Plus™	C
Grey Bond®	E
Gold Bond®	Y

Wall Trax™ Baskets

• Attach quickly and easily to Wall Trax™ system

Model No.	W x L x H (In.) (mm.)		Weight (Lb.) (Kg)	
GB12246	12 x 24 x 6	305 x 610 x 150	4	2
GB12186	12 x 18 x 6	305 x 457 x 150	3	1
GB18143	14 x 18 x 3	355 x 457 x 76	3	1
GBSPRNK	5 x 12 x 4	126 x 305 x 102	1	1.5
GB4512**	5 x 12 x 4	126 x 305 x 102	1	1.5
GB4418R1	4 x 18 x 4	102 x 457 x 102	1.5	2
GB12106	12 x 10 x 6	254 x 305 x 150	2.5	1
GB3420	4 x 20 x 3	102 x 508 x 76	3	1



Wall Trax™ Holders

Model No.	W x L x H (In.) (mm.)		Weight (Lbs.) (Kg.)	
Bottle Holder				
GRBTLHD	4 x 21 x 13	102 x 533 x 330	2	1
Scoop Holder				
GRSCOOP	5 x 10 x 6	127 x 254 x 150	1	0.6



Hooks

Model No.	Description	W x L x H (In.) (mm.)		Weight (Lbs.) (Kg.)	
HOOK24	24" Hook, seven 6" prongs	7 x 24 x 6.5	182 x 603 x 165	2	1
HOOK12	12" Hook, four 6" prongs	7 x 12 x 6.5	182 x 305 x 165	1	0.5
PHK	Pot Hook				

Label Holders for Inverted Shelves

Model No.	Length (In.)	Fits Shelf Length (In.)	For Labels W x L (In.)
ISBM36	32.5	36	1 x 32
ISBM48	44.5	48	1 x 44

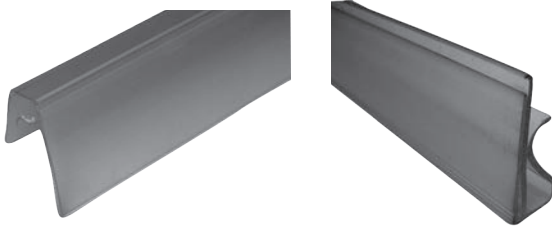

Clear Covered Label Holders

- Insert paper label from top
- Label is protected by clear plastic face
- Available in clear only

Model No.	Length (In.)	Fits Shelf Length (In.)	For Labels W x L (In.)
PTBM36	32	36	1 x 32
PTBM48	44	48	1 x 44

Additional sizes are available, call for details.

Label Holders For Paper Labels — Slotted Style

Model No.	Length (In.)	Fits Shelf Width (In.)	For Labels W x L (In.)
BM1	3	All	Up to 1 x 3
BM24	20	24	Up to 1 x 20
BM36	32	36	Up to 1 x 32
BM48	44	48	Up to 1 x 44
BM60	56	60	Up to 1 x 56
BM72	68	72	Up to 1 x 68

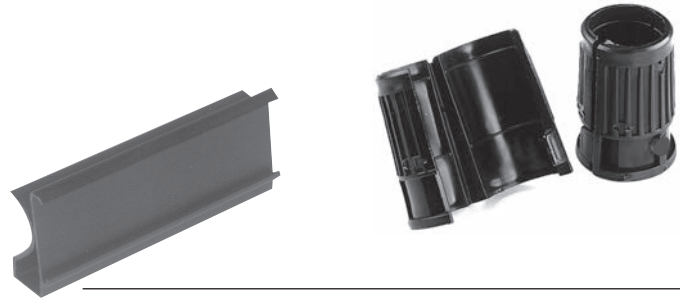

ISS™ Sure-Lock™

Model No.	Description
PCS3	Sure Lock™ Set of 8 Round Plastic

Stainless Steel Shelf Covers

- 300 Series stainless steel — fit on top of wire shelving

Model No.	W x L x H (In. / mm.)		Weight (Lbs. / Kg.)	
1836SCT	18 x 36	457 x 914	15	7
1848SCT	18 x 48	457 x 1219	20	9
2436SCT	24 x 36	610 x 914	18	8
2448SCT	24 x 48	610 x 1219	24	11
3036SCT	30 x 36	762 x 914	20	9
3048SCT	30 x 48	762 x 1219	23	10



Shelf Gard™ Polyethylene Shelf Covers

Opaque Model No.	Clear Model No.	W x L (In.)	Weight (Lbs.) (Kg.)	
1424PSG	1424CPSPG	14 x 24	1.5	1
1436PSG	1436CPSPG	14 x 36	1.5	1
1448PSG	1448CPSPG	14 x 48	2	1
1460PSG	1460CPSPG	14 x 60	2.5	1
1824PSG	1824CPSPG	18 x 24	1.5	1
1836PSG	1836CPSPG	18 x 36	2	1
1848PSG	1848CPSPG	18 x 48	2.5	1
1860PSG	1860CPSPG	18 x 60	3	1
2424PSG	2424CPSPG	24 x 24	2	1
2436PSG	2436CPSPG	24 x 36	2.5	1
2448PSG	2448CPSPG	24 x 48	4	1.5
2460PSG	2460CPSPG	24 x 60	4	2



ISS Contender™ Accessories

S-Hooks

- Use two per shelf to continue a run of shelving or in corners

Model No.	Finish
MCB1C	Plating Plus™



Shelf Support Clips

Model No.	Description
ICMKIT	Plastic clips (4-Pack)



Label Holders For Adhesive Labels

- Attach adhesive label to flat face of holder
- Available in blue only

Model No.	Length (In.)	Fits Shelf Length (In.)	For Labels W x L (In.)
PFBM3	3	All	Up to 1 x 3
PFBM18	14	18	Up to 1 x 18
PFBM24	20	24	Up to 1 x 20
PFBM30	26	30	Up to 1 x 26
PFBM36	32	36	Up to 1 x 32
PFBM42	38	42	Up to 1 x 38
PFBM48	44	44	Up to 1 x 44
PFBM54	50	54	Up to 1 x 54
PFBM60	56	56	Up to 1 x 56
PFBM72	68	68	Up to 1 x 68

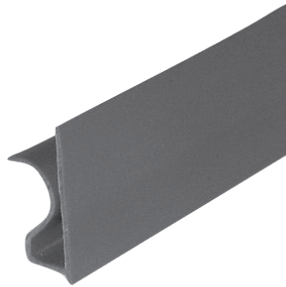

SPG's foodservice products are all manufactured to meet NSF standards. For specific items, visit www.nsf.org

Kelmax Accessories

Meat Lugs

- Fits Kelmax Meat Lug Carts
- High impact polyurethane
- Formed base for cross stacking
- Lids available



Model No.	Color	L x W x H (In.)	L x W x H (mm.)	Weight (Lbs.)	Weight (Kg.)
4K0232 (Lug)	Grey	25 x 16 x 9	635 x 406 x 229	3	1
4K0236 (Lug)	White	25 x 16 x 9	635 x 406 x 229	3	1
4K0510 (Lid)	Grey	25 x 16 x 2	641 x 413 x 51	2	1
4K0235 (Lid)	White	25 x 16 x 2	641 x 413 x 51	2	1

Kelmax Meat Lugs are available in a variety of sizes

Platters and Trays

- High impact polystyrene
- Ribbed for support with reinforced edges
- Shipped 12 per case



Model No.	Color	(In.)	(mm.)	(Lbs.)	(Kg.)
4K0238	White	12 x 24	305 x 610	28	13
4K0240	White	12 x 30	305 x 762	35	16
4K0243	White	18 x 26	305 x 660	40	18

Knife Racks

- Stainless steel— comes with black insert as standard



Model No	Insert Color	(In.)	L x W x H (mm.)	Weight (Lbs.)	Weight (Kg.)
4K0418	Black	12 x 2.5 x 13	305 x 63.5 x 340	3	1

Universal® Stainless Accessories

8" Center Splash Mount Faucet

Standard Duty Model No.	Heavy Duty Model No.	Spout Size (In.) (mm.)	
USF-8-S	F-3251	8	203
USF-10-S	F-3252	10	254
USF-12-S	F-3253	12	305
USF-14-S	F-3254	14	356

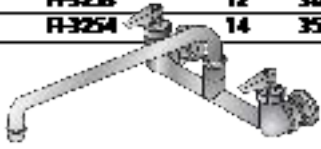

8" Center Deck Mount Faucet

Standard Duty Model No.	Heavy Duty Model No.	Spout Size (In.) (mm.)	
USF-8-D	F-3311	8	203
USF-12-D	F-3313	12	305

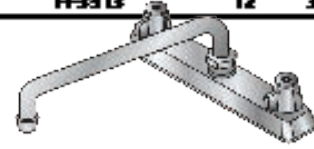

Twist Handle Lever Drains

Model No.	Description
US-LD	Can be adapted for 1.5 or 2" drain



Pre-Rinse Faucets & Accessories

Model No.	Description
FI-2210	Pre-Rinse Wall Mount Faucet*
KV-01	Knee Valve
FV-02	Foot Valve
GS-03	Gooseneck Spout
USFK154000	Gooseneck Faucet / 4" Center P-TRAP — Chrome Plated

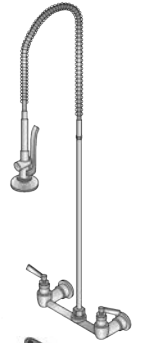

*Includes wall bracket

Mop Hanger

Model No.	L x W (In.) (mm.)		Approx. Wt. (Lbs.) (Kg.)	
MH-3	3 x 18	76 x 457	3	1

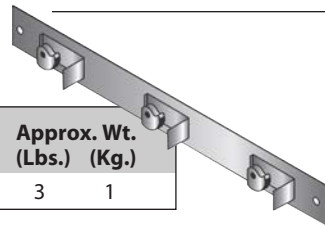

Service Faucet

Model No.	Approx. Wt. (Lbs.) (Kg.)	
SF-8	5	2

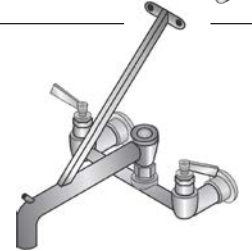

Soak Sink Baskets

Model No.	L x W (In.) (mm.)		Approx. Wt. (Lbs.) (Kg.)	
DTO-25-1620	16 x 20	406 x 508	15	7
DTO-25-2020	20 x 20	508 x 508	20	9
DTO-25-2424	24 x 24	610 x 610	22	10

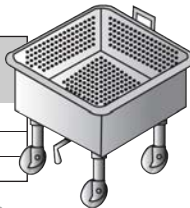

Mobile Sinks

Model No.	Bowl L x W x D (In.) (mm.)		Approx. Wt. (Lbs.) (Kg.)	
DTO-1620	16 x 20 x 12	406 x 508 x 305	35	16
DTO-2020	20 x 20 x 12	508 x 508 x 305	40	18
DTO-2424	24 x 24 x 12	610 x 610 x 305	50	23

Hose Hanger

Model No.	L x W (In.) (mm.)		Approx. Wt. (Lbs.) (Kg.)	
MH-1	3 x 6	76 x 152	2	1

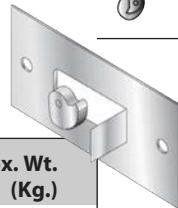

Dish Table Accessories

Model No.	Description	Approx. Wt. (Lbs.) (Kg.)	
DTO-17	Rubber Scrap Block (does not include hole)	5	2
DTO-27	Surface Mount Stainless Steel Rack Slide	5	2



Scrap Basket

Model No.	Description	L x W x H (In.) (mm.)		Approx. Wt. (Lbs.) (Kg.)	
DTO-10	Stainless Steel Scrap Basket (Includes slide rack)	19.5 x 19.5 x 6	495 x 495 x 152	35	16

Table-Mount Overshelves

- Sold by the linear foot
- 16-ga. 300 Series stainless steel with all sides formed down 1-1/2" at 90 degrees and back 1/2" at 45 degrees
- Legs are made from 1-5/8" stainless steel tubing
- Standard shelf height for single overshelf is 18" — for double overshelf, it is 18" from table to first shelf and 14" from first shelf to second shelf
- Shelves 84" or longer require 6 legs



Approx. Wt. Model No	Shelf Width (In.)	Shelf Width (mm.)	Weight/Linear Foot (Lbs.) (Kg.)	
Single Overshelf				
TSS-18-10	10	254	3	1
TSS-18-12	12	305	4	2
TSS-18-14	14	356	5	2
TSS-18-16	16	406	6	3
Double Overshelf				
TSD-18-10	10	254	6	3
TSD-18-12	12	305	8	4
TSD-18-14	14	356	10	4.5
TSD-18-16	16	406	12	5.5

Cantilever Overshelves

- Requires factory installation — manufactured from 16-ga. 300 Series stainless steel with rear turned up 2"
- Front and ends formed down 1-1/2" at 90 degrees and back 1/2" at 45 degrees
- Shelves are supported with 1-5/8" O.D. stainless steel tubing and 16-ga. brackets
- Shelves 84" or longer require 3 legs

Model No.	Shelf Width (In.)	Shelf Width (mm.)	Weight/Linear Foot (Lbs.) (Kg.)	
COS-18-10	10	254	4	2
COS-18-12	12	305	5	2
COS-18-14	14	356	6	3
COS-18-16	16	406	7	3

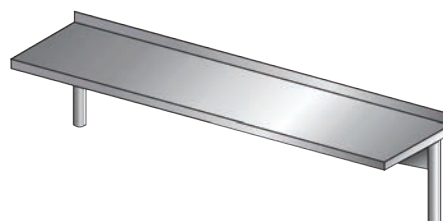

Circular Ceiling Mounted Pot Racks

- All stainless steel construction
- Choose from 4' to 8' lengths
- Pot rack bars fabricated from 3/16" x 2" flat bar stainless steel
- Ceiling mount support bars are 24" long

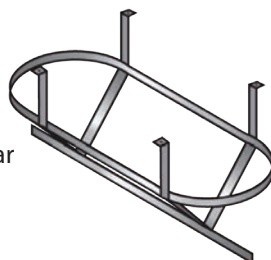

Model No.	Length (In.)	Length (mm.)	Approx. Weight (Lbs.) (Kg)		Cubic Ft.
PR-C-48-S	48	1219	34	15	14
PR-C-60-S	60	1524	39	18	18
PR-C-72-S	72	1829	44	20	21
PR-C-84-S	84	2134	49	22	24
PR-C-96-S	96	2438	54	25	28

Circular Table Mounted Pot Racks

- All stainless steel construction
- Racks are mounted through table tops and secured to undershelf or crossrails
- Pot rack bars (3/16" x 2" stainless steel) are fully welded to stainless steel sleeves which slide over the 1-5/8" stainless tube uprights
- Stainless steel pot hooks supplied, three every 12"
- Factory installation required

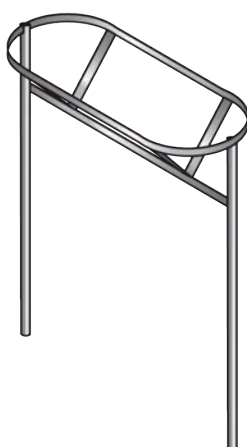

Cubic Model No.	Length (In.)	Length (mm.)	Approx. Weight (Lbs.) (Kg)		Cubic Ft.
TPR-48-S	42	1067	35	16	14
TPR-60-S	54	1372	39	8	18
TPR-72-S	66	1676	43	20	21
TPR-84-S	78	1981	50	23	24
TPR-96-S	90	2286	56	25	28
TPR-108-S	102	2591	61	28	31
TPR-120-S	114	2896	66	30	35

Pot Rack Shelves

- Manufactured from 16-ga. 300 Series stainless steel
- Adjustable in height
- Available in 12" width, and 4' to 10' lengths
- Circular Table Mounted Pot Rack sold separately
- Factory installation required

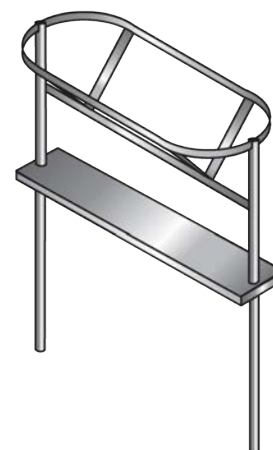

Model No.	Length (In.)	Length (mm.)	Approx. Weight (Lbs.) (Kg)		Cubic Ft.
PRS-1248	12 x 48	305 x 1219	18	8	2
PRS-1260	12 x 60	305 x 1524	23	10	2
PRS-1272	12 x 72	305 x 1829	28	13	3
PRS-1284	12 x 84	305 x 2134	33	15	4
PRS-1296	12 x 96	305 x 2438	38	17	4
PRS-12108	12 x 108	305 x 2743	43	20	5
PRS-12120	12 x 120	305 x 3048	48	22	5

Sink Bowls Integral with Table Tops

Model No.	L x W x H		Approx. Weight	
	(In.)	(mm.)	(Lbs.)	(Kg)
SB-161812	16 x 18 x 12	406 x 457 x 305	20	9
SB-162012	16 x 20 x 12	406 x 508 x 305	21	10
SB-181812	18 x 18 x 12	457 x 457 x 305	22	10
SB-182412	18 x 24 x 12	457 x 610 x 305	30	14
SB-202012	20 x 20 x 12	508 x 508 x 305	25	11
SB-242412	24 x 24 x 12	610 x 610 x 305	35	16
SB-202812	20 x 28 x 12	508 x 711 x 305	33	15
SB-243012	24 x 30 x 12	610 x 762 x 305	39	18
SB-303012	30 x 30 x 12	762 x 762 x 305	43	20

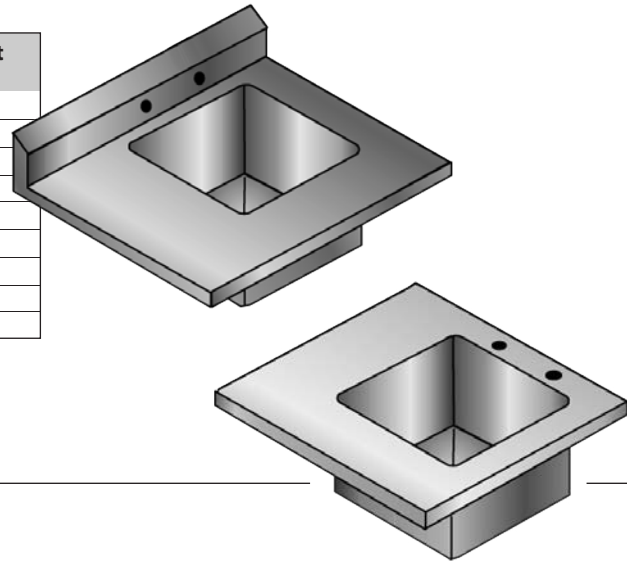

Roller Bearing Drawers

- Lock included
- The enclosed 3-tier drawer unit includes a stainless steel top if ordered as a stand-alone unit — does not include top when integral with table

Model No.	Pan Type	(In.)	(mm.)	(Lbs.)	(Kg)
Single Drawer - Self-Closing Design					
TAC-1520-S	Stainless Steel	15 x 20	381 x 508	20	9
TAC-2020-S	Stainless Steel	20 x 20	508 x 508	25	11
Enclosed 3-Tier Drawer Unit					
TAC-3T-15-S	Stainless Steel	15 x 20	381 x 508	110	50
TAC-3T-20-S	Stainless Steel	20 x 20	508 x 508	125	57



Stainless Steel Undershelf

- 18-ga. stainless steel
- Sold by the linear foot

Model No.	Description	Approx. Weight (Lbs.) (Kg.)	
DTO-US-24	24" Wide Shelf	4	2
DTO-US-30	30" Wide Shelf	5	2

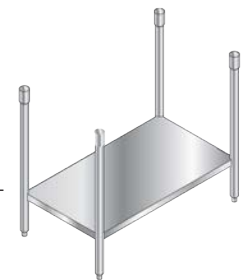

Door Locks

Model No.	Description
Lock-H	Hinged Doors
Lock-S	Sliding Doors



SPG's foodservice products are all manufactured to meet NSF standards. For specific items, visit www.nsf.org

SPG has a complete line of casters to keep your business on a roll.

Casters are available in plate, threaded stem, square stem and round post mountings. When selecting casters, consider capacity, the maximum weight the caster will need to support as well as size, fastening, flooring and environmental conditions. Wheel materials are solid rubber, polyolefin, polyurethane and phenolic.



Rigid Plate Caster



Swivel Plate Caster

SPG Plate Casters

Model No.	Swivel/Rigid	Material	Dia. (In.)	Face (In.)	Capacity (Lbs.)	Fits	Unit	Brakes	Weight (Lbs.) (Kg.)	
CP5PR	Rigid	Polyurethane	5	1	300	ISS, ISS Contender	Ea.	NA	3	1
CP8PR	Rigid	Polyurethane	8	2	900	ISS, ISS Contender	Ea.	NA	10.5	5
CP5P	Swivel	Polyurethane	5	1	300	ISS, ISS Contender	Ea.	NA	3	1
CP5PB	Swivel	Polyurethane	5	1	300	ISS, ISS Contender	Ea.	✓	3	1
4K0298	Rigid	Polyurethane	6	2	2,000	Kelmax	Ea.	NA	4.5	2
4K0279	Rigid	Polyurethane	5	1.5	600	Kelmax	Ea.	NA	2	1
4K4690	Swivel	Phenolic Hi-Temp(Green)	4	1.5	—	Kelmax	Ea.	NA	2	1
4K1495	Swivel	Phenolic Hi-Temp	4	1.5	—	Kelmax	Ea.	NA	—	—
4K0321	Swivel	Phenolic Hi-Temp SS Rig	4	1.5	—	Kelmax	Ea.	NA	—	—
4K0324	Swivel	Polyurethane	4	1.5	600	Kelmax	Ea.	NA	2	1
4K0333	Swivel	Polyurethane	5	1.5	600	Kelmax	Ea.	NA	2.5	1

Caster Material Guide

Here's a brief overview of the four main types of caster wheel types:

Polyurethane

- Tough abrasion resistant
- Excellent floor protection and ease of rolling
- Wide temperature range -30° F to 180° F

Resilient Rubber

- Resilient casters are great for use on rough flooring
- Long lasting performance, quiet and economical

Polyolefin

- Good general use hard plastic casters
- Good on concrete surfaces

Phenolic Material

High temperature material for use in ovens up to 550° F



SPG's foodservice products are all manufactured to meet NSF standards. For specific items, visit www.nsf.org



Stem Caster without brake



Stem Caster with brake

SPG Stem Casters

Model No.	Type	Swivel/Rigid	Material	Dia. (In.)	Face (In.)	Capacity (Lbs.)	Fits	Unit	Brakes	Weight (Lbs.) (Kg.)
CP5PR	Expandable, Stem	Swivel	Resilient Rubber	3	1	150	AMCO. ISS, ISS Contender	Ea.	NA	2 1
CM3MB	Expandable, Stem	Swivel	Resilient Rubber	3	1	150	AMCO. ISS, ISS Contender	Ea.	✓	2 1
CM5M	Expandable, Stem	Swivel	Resilient Rubber	5	1	200	AMCO. ISS, ISS Contender	Ea.	NA	2 1
CM5MB	Expandable, Stem	Swivel	Resilient Rubber	5	1	200	AMCO. ISS, ISS Contender	Ea.	✓	2 1
CM5P	Expandable, Stem	Swivel	Polyurethane	5	1	300	AMCO. ISS, ISS Contender	Ea.	NA	2 1
CM5PB	Expandable, Stem	Swivel	Polyurethane	5	1	300	AMCO. ISS, ISS Contender	Ea.	✓	2 1
AC7B	Stem	Swivel/Rigid	Polyurethane	5	1	250	AMCO	Ea.	✓	3 1
AC8RS	Stem	Swivel	Polyurethane	5	1	250	AMCO	Ea.	NA	3 1
IMPCAS5	Threaded Stem	Swivel	Polyurethane	5	1	250/Set	ISS Contender	Set(4)	✓*	6 3
4K1196	Expandable Stem for 1" Tube	Swivel	Polyurethane	5	1	—	Kelmax	Ea.	NA	2 1
4K0307	Square Stem	Swivel	Polyurethane	5	1.5	—	Kelmax	Ea.	NA	2 1
TAC-1-4	Stem	Swivel	Polyurethane	5	1	250	Universal	Set(4)	✓*	11 5
TAC-2-6	Stem	Swivel	Polyurethane	5	1	250	Universal	Set(6)	✓*	14 6

*Includes 2 brakes in the set

Donut Bumpers

Model No.	Width (In.)	Description
ADONUT	5	Revolving
DONUT2	3½	Non-Revolving

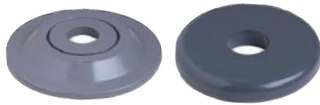

Caster Channels

- Required on all round stem rigid casters to maintain aligned position of casters
- Order one caster channel for each pair of rigid casters
- Select caster channel length based on shelf width











Plating Plus™ Model No.	Fits Shelf Width (In.)	W x L (In.)	W x L (mm.)	Weight (Lbs.) (Kg.)
CC18C	18	2 x 19	57 x 476	1 1
CC21C	21	2 x 22	57 x 553	1.5 1
CC24C	24	2 x 25	57 x 629	2 1

We Don't Just Offer More Choices, We Offer Better Ones.

We invite you to explore this catalog and the many solutions we offer to your operation. While the products you see on these pages are representative of the extraordinary quality we offer, please remember that they are only a fraction of the foodservice equipment we manufacture.

In addition to the widest selection of storage products available — SPG also offers the technical expertise to help you integrate them into a system that will optimize the functionality of your space, increase the efficiency of your staff and maximize the long-term value of your investment.

	Shelving	12
	Speed Of Service	41
	Carts	43
	Racks	49
	Tables	55
	Sinks	63
	Bar Equipment	65
	Backroom	67
	Accessories/Casters	69



Scan here to see our full-line Foodservice Catalog.

For more information about SPG products visit our website at spgusa.com, email us at customerservice@spgusa.com or call 877-503-4SPG (4774).

AMCO® • FREESTYLE® • ISS™ • ISS CONTENDER™
KELMAX • UNIVERSAL® STAINLESS • GILLIS • JARKE®



<http://www.youtube.com/user/StorageProductsGroup>

See SPG's Terms & Conditions at <http://spgusa.com/termsofsale.html>

EXPECT MORE

SPG™
STORAGE PRODUCTS GROUP

SPG International, LLC
3340 Peachtree Road NE
Suite 1250
Atlanta, GA 30326
tel. 877-503-4SPG (4774)
fax 800-577-2210
www.spgusa.com